

Hughes No. 3107 POLE BAND TEST

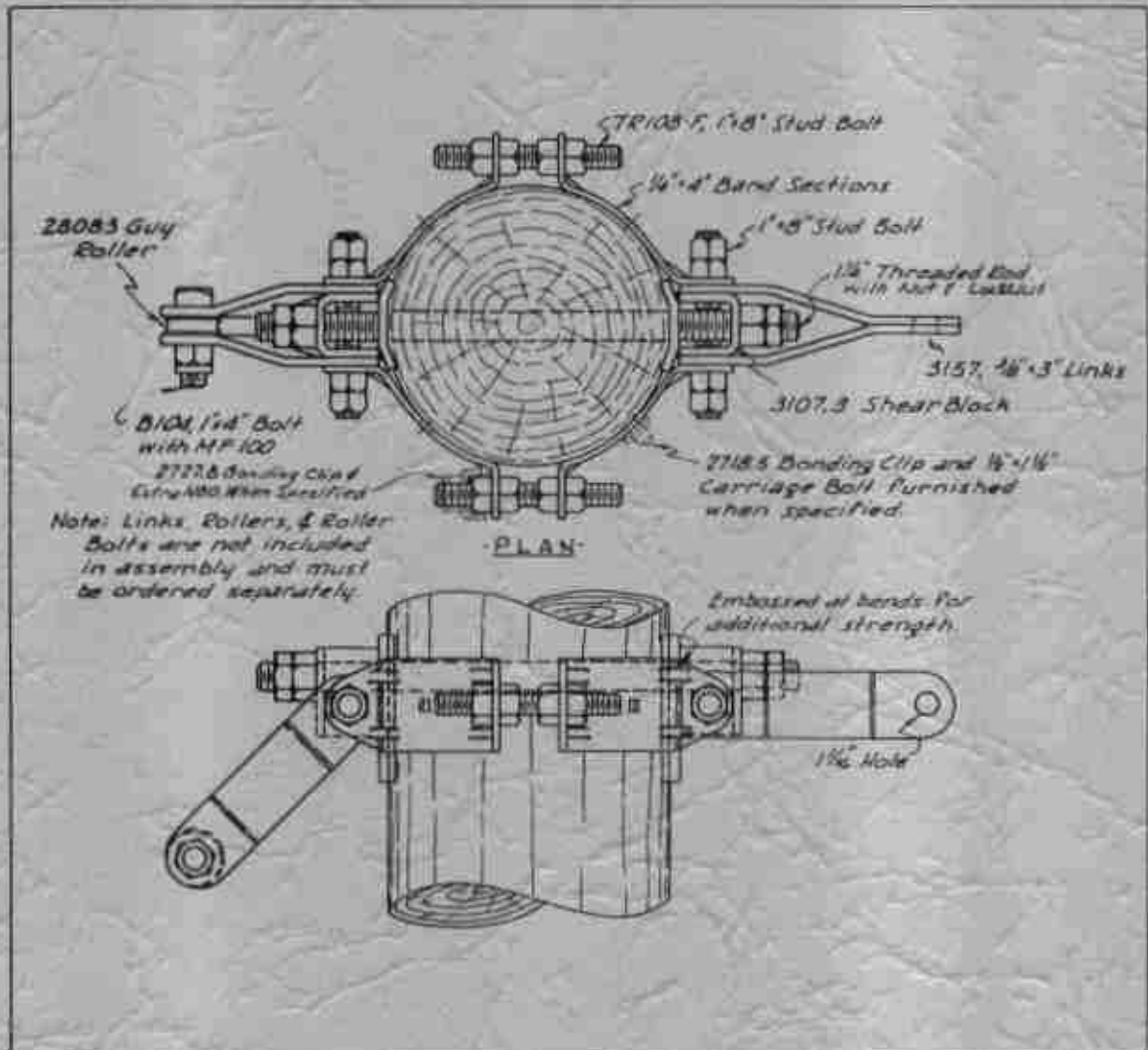

HUGHES
BROTHERS

P.O. Box 159, 210 N. 13th Street, Seward, Nebraska 68434 • Phone 402/643-2991 Telex 438076

Band No. 3107.5 = 8" to 10" Pole Diam.
 " 3107.6 = 10" to 12" " "
 " 3107.7 = 12" to 14" " "
 " 3107.8 = 14" to 16" " "
 " 3107.9 = 16" to 18" " "
 " 3107.10 = 18" to 20" " "

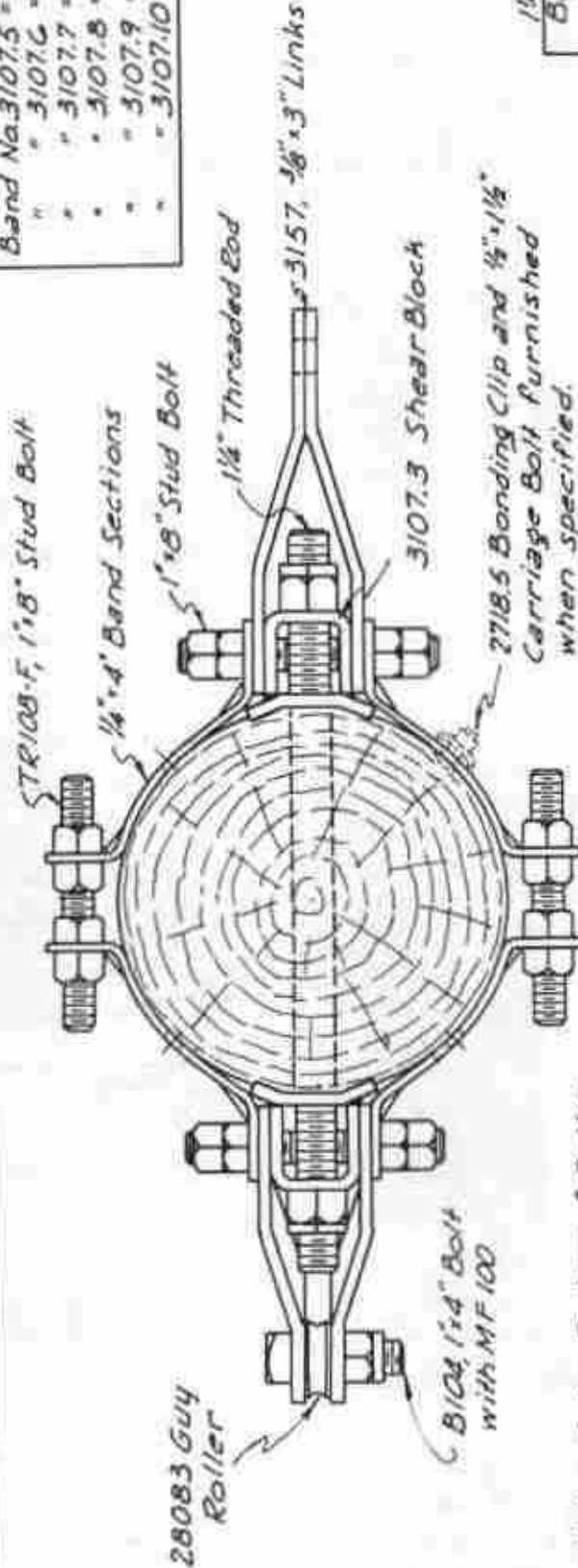

PLAN

Note: Links, Rollers, & Roller Bolts are not included in assembly and must be ordered separately.

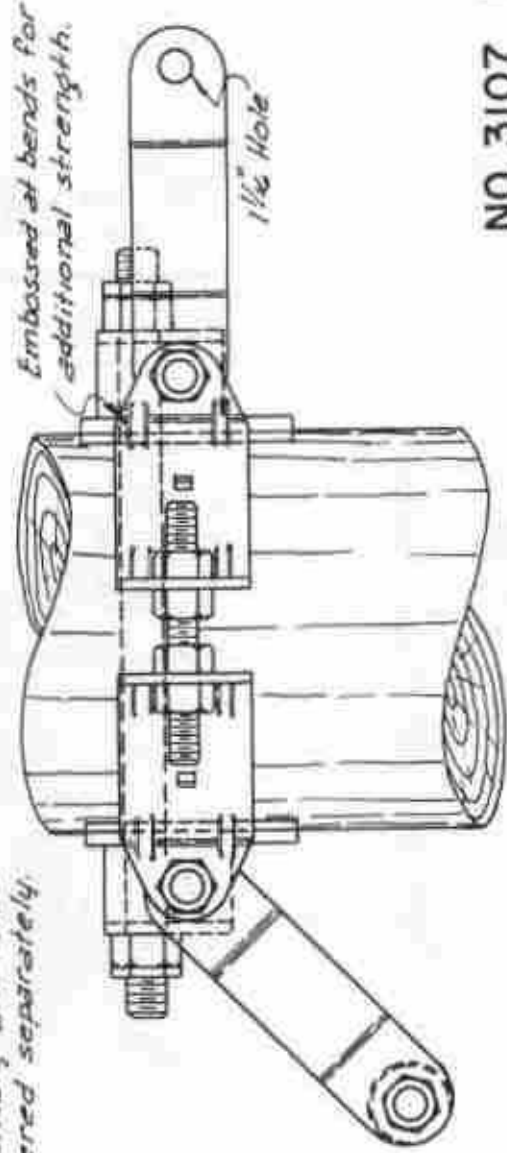

ELEVATION

Band No.	Thrd Rod Length
3107.5	20" 7 x 5"
3107.6	22" 7 x 5"
3107.7	24" 7 x 5"
3107.8	26" 7 x 5"
3107.9	28" 7 x 5"
3107.10	30" 7 x 5"

NO. 3107 POLE BAND



HUGHES SEWARD BROTHERS NEBRASKA INCORPORATED
 FOUNDED - 1911

APPROVED
 APPLICABLE

DRG. NO. 3107

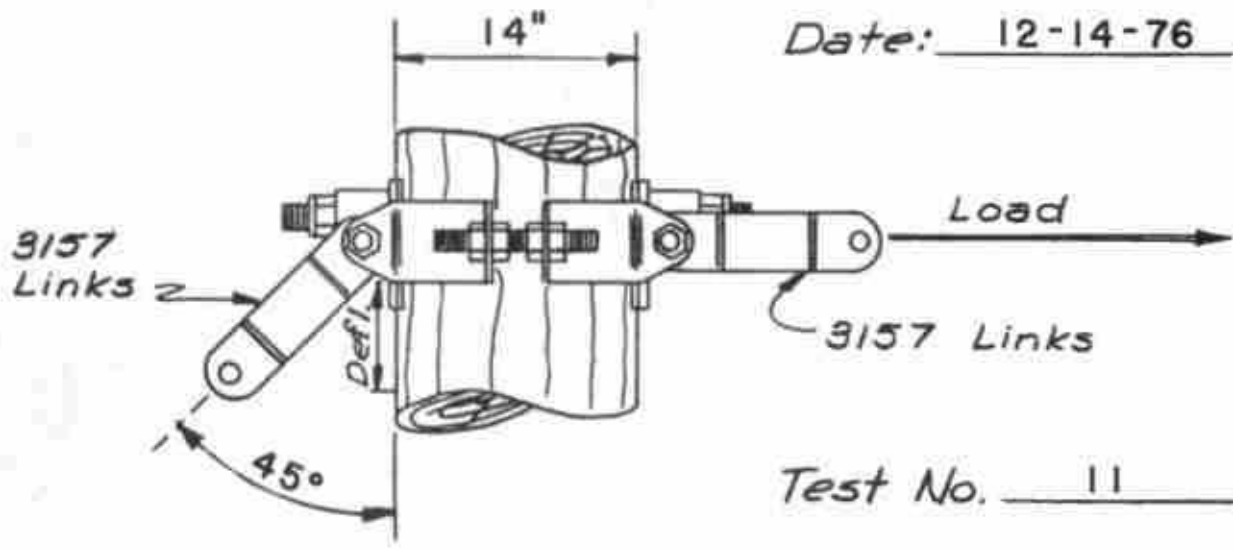

Date: 12-14-76

Test No. 11

DATA

LOAD	CALCULATED GUY LOAD	DEFL.	PIC. No.	REMARKS
0	0	0	1	
8000	11134	0	2	
16000	22627	1/8"	3	
24000	33941	1/8"	4	
32000	45255	3/8"	5	
39000	55154		6	Failure of Guying Shackle
0	0		7	Reload
44000	62225		8	End of Loading,
				Elongation of
				Guying Link Holes

No. 3107 POLE BAND TEST
45 DEGREE GUYING ANGLE

Drawn D. POLICKY
 Appr.
 Appr.

HUGHES
SEWARD
 FOUNDED - 1921



BROTHERS
NEBRASKA
 INCORPORATED

DRG. NO.
A-2136-F1

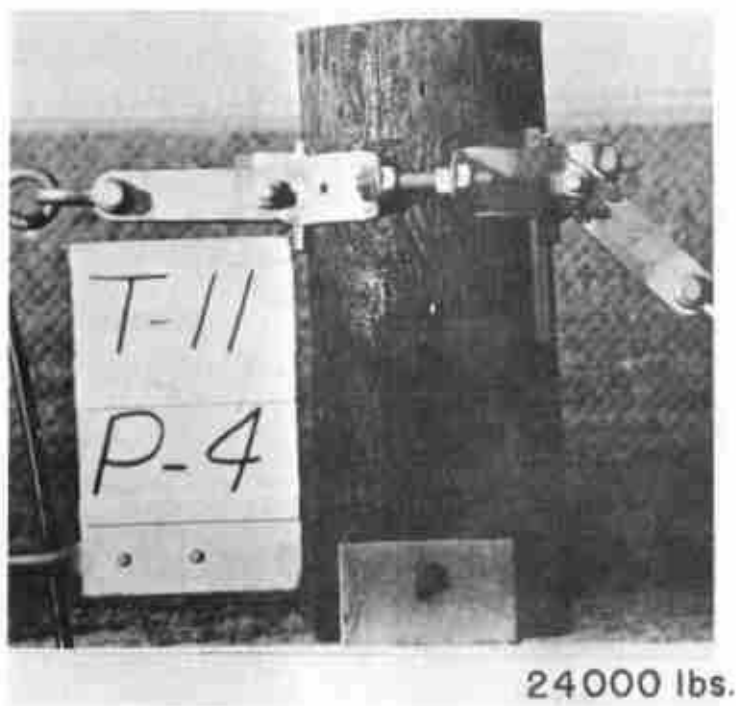
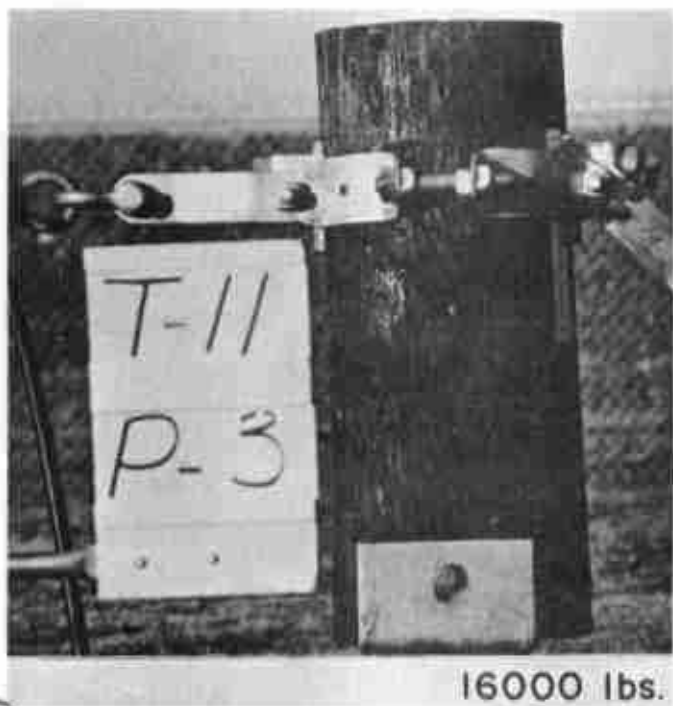
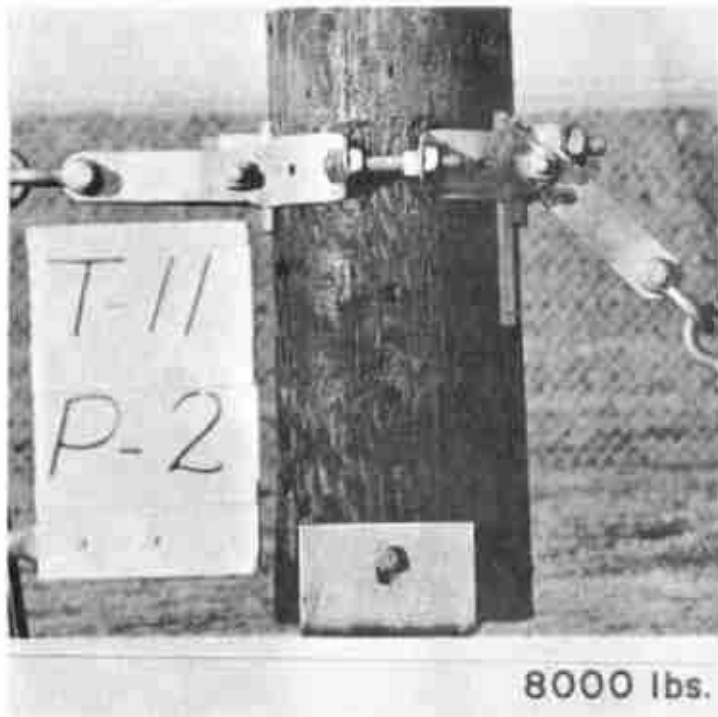
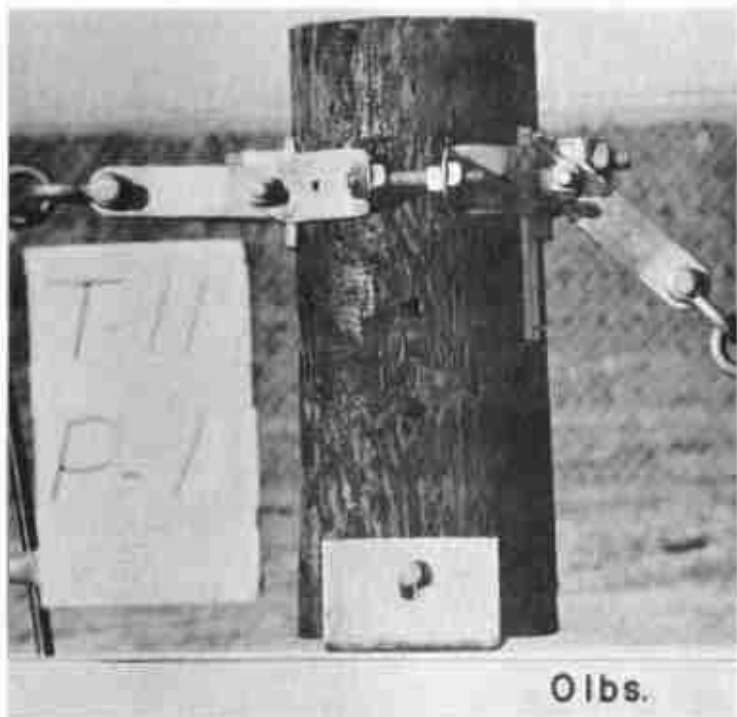

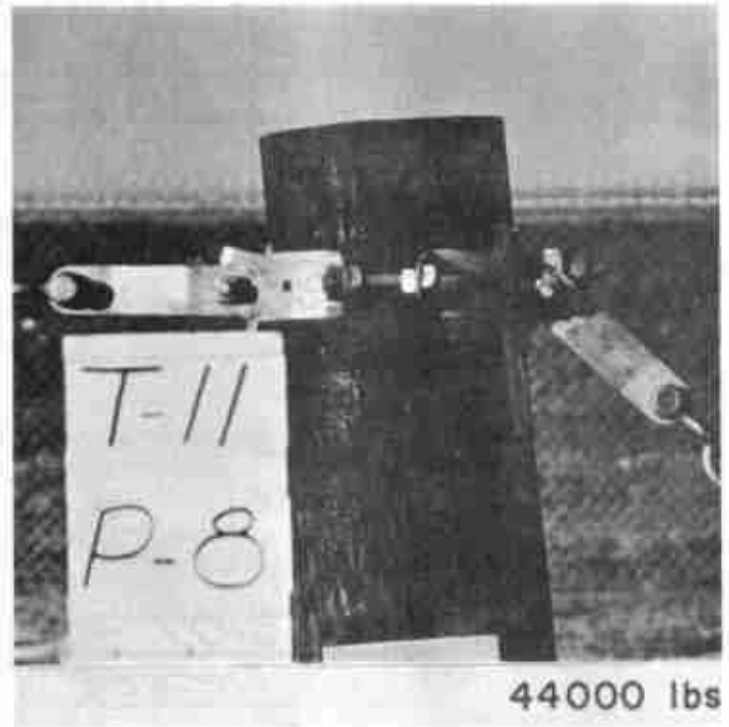
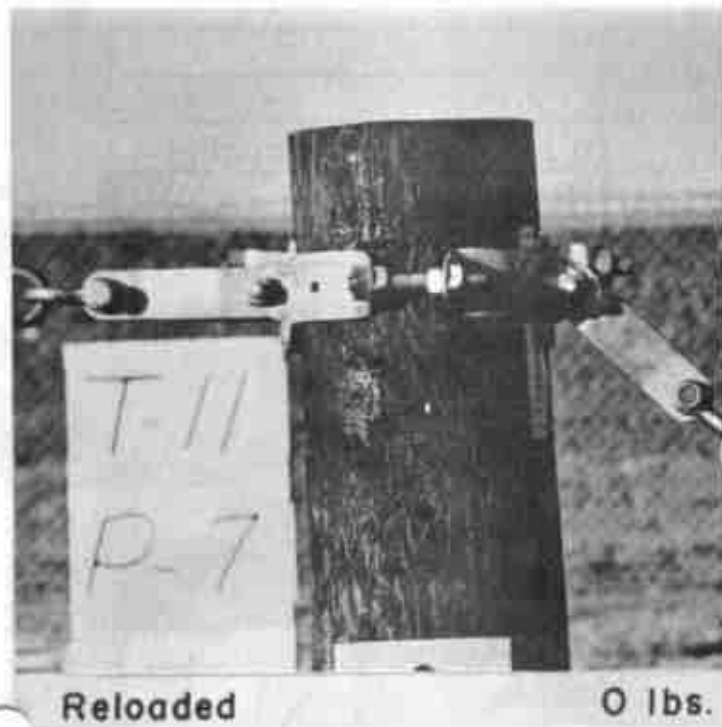
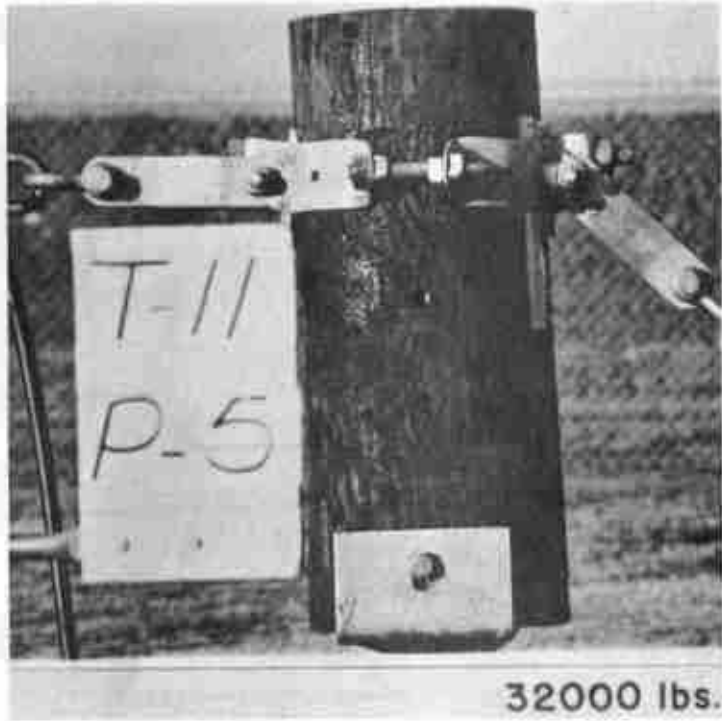

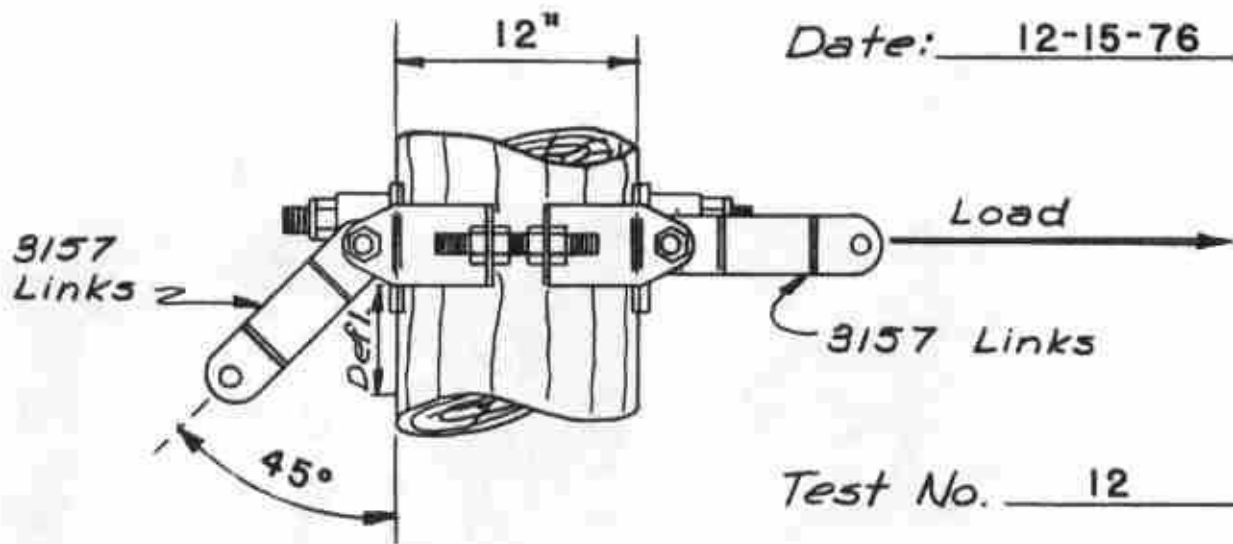

DATA

LOAD	CALCULATED GUY LOAD	DEFL.	PIC. No.	REMARKS
0	0	0	1	
8000	11314	0	2	
16000	22627	1/8"	3	
24000	33941	1/4"	4	
32000	45255	1/2"	5	5 Min. Delay in Loading
46400	65620	1 1/2"	6	No Failure

No. 3107 POLE BAND TEST
45 DEGREE GUYING ANGLE

Drawn **D. POLICKY**
Appr.
Appr.

HUGHES
SEWARD
FOUNDED - 1921



BROTHERS
NEBRASKA
INCORPORATED

DRG. NO.
A-2136-F2



0 lbs.

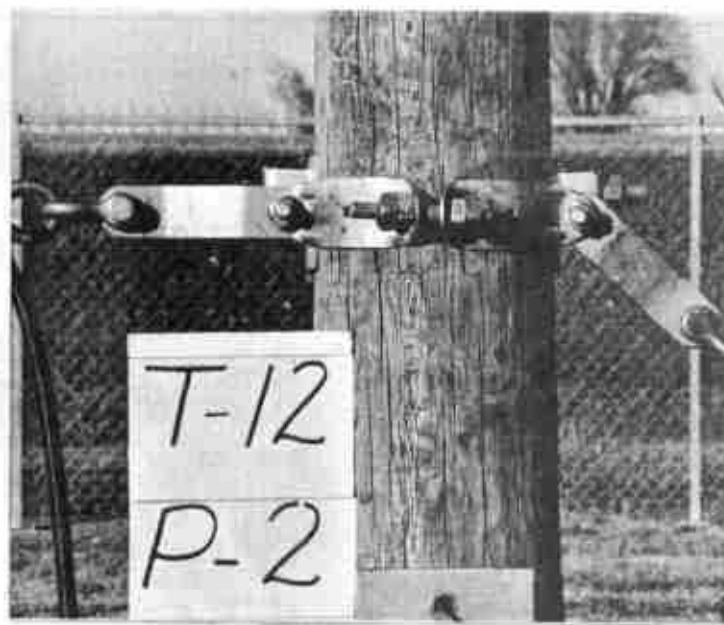

8000 lbs.



16000 lbs.

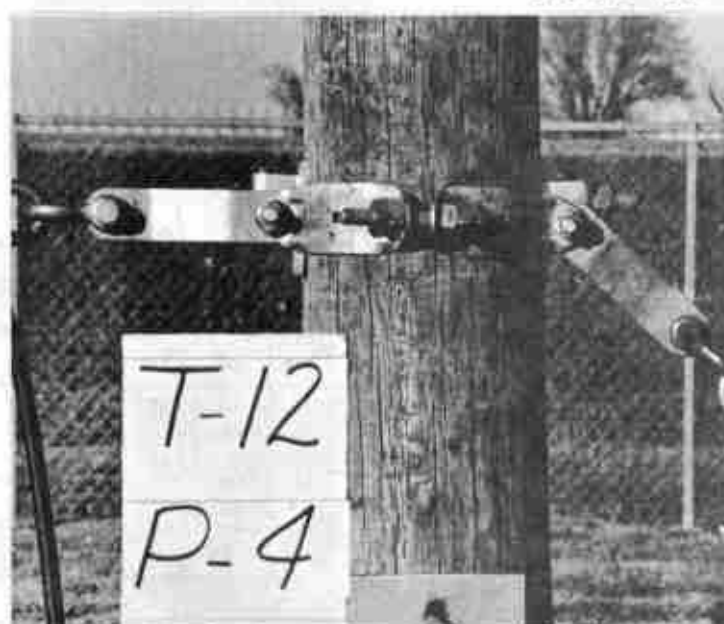

24000 lbs.



32000 lbs.



40000 lbs.

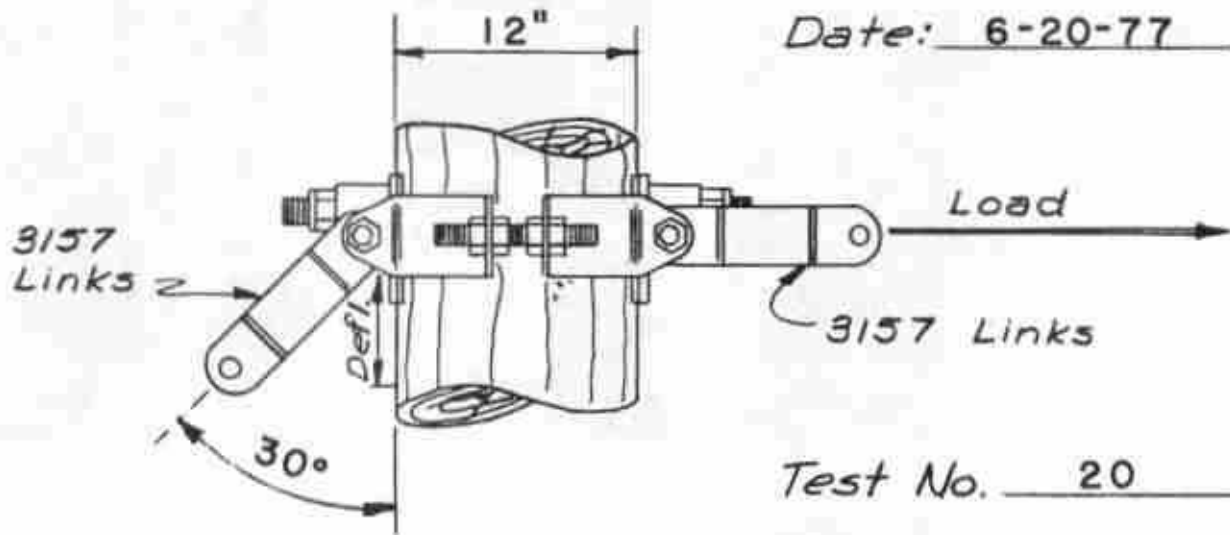

Date: 6-20-77

Test No. 20

DATA

LOAD	CALCULATED GUY LOAD	DEFL.	PIC. No.	REMARKS
0	0	0	1	
8000	16000	1/4"	2	
11500	23000	1/4"	3	
16000	32000	1/2"	4	
24000	48000	1 1/4"	5	
30000	60000		6	Failure of Guying Shackle
30000	60000		7	Reload, Failure of Guying Links

No. 3107 POLE BAND TEST
30 DEGREE GUYING ANGLE

Drawn D. POLICKY
Appr.
Appr.

HUGHES SEWARD
FOUNDED - 1921



BROTHERS NEBRASKA
INCORPORATED

DRG. NO.
A-2136-F3



0 lbs.



8000 lbs



11500 lbs.



16000 lbs.



24000 lbs.



Failure

30000 lbs.



Failure

30000 lbs.