

ASSESSMENT OF DOWEL BAR RESEARCH

Iowa DOT Project HR-1080
CTRE Project 00-93

Sponsored by
the Iowa Department of Transportation



Iowa Department
of Transportation



*Center for Transportation
Research and Education*

Center for Portland Cement Concrete Pavement Technology
Department of Civil and Construction Engineering

IOWA STATE UNIVERSITY

Final Report • August 2002

Assessment of Dowel Bar Research

Abstract

This report presents the latest technological gaps in dowel bar research based upon completed and ongoing dowel bar research from across the nation. In order to obtain this collection of information about dowel bars, a search was conducted on a nationwide level. The technological gaps and duplications of the research were then determined. In addition, this report also provides a brief annotated bibliography of all sources used to determine the gaps in technology and knowledge for dowel bar and alternative dowel bar topics as applied to highway pavements.

The contents of this report do not represent a warranty of the products used on behalf of the State of Iowa, Iowa State University, Iowa Department of Transportation, or the authors. The opinions, findings and conclusions expressed in this publication are those of the authors and not necessarily those of the Highway Division of the Iowa Department of Transportation. Engineering data, designs, and suggested conclusions should not be used without first securing competent advice with respect to the suitability for any given application. The responsibility for the use of information in this report remains with the user. This report is for information purposes and is made available with the understanding that it will not be cited without permission of the authors.

CTRE's mission is to develop and implement innovative methods, materials, and technologies for improving transportation efficiency, safety, and reliability while improving the learning environment of students, faculty, and staff in transportation-related fields.

ASSESSMENT OF DOWEL BAR RESEARCH

Iowa DOT Project HR-1080
CTRE Project 00-93

Principal Investigator

Max L. Porter
Professor of Civil Engineering, Iowa State University

Research Assistant

Robert J. Guinn, Jr.
Graduate Assistant

Authors

Max L. Porter and Robert J. Guinn, Jr.

Preparation of this report was financed in part through funds provided by the Iowa Department of Transportation through its research management agreement with the Center for Transportation Research and Education.

Center for Transportation Research and Education

Iowa State University
2901 South Loop Drive, Suite 3100
Ames, IA 50010-8632
Phone: 515-294-8103
Fax: 515-294-0467
www.ctre.iastate.edu

Final Report • August 2002

TABLE OF CONTENTS

| | |
|--|----------|
| INTRODUCTION..... | 1 |
| OBJECTIVE AND SCOPE | 4 |
| Objective..... | 4 |
| Scope..... | 4 |
| BACKGROUND..... | 5 |
| Previous Dowel Bar Projects and Reports..... | 6 |
| Report: “ <i>The Design of Plain Doweled Jointed Concrete Pavement</i> ” (1989) [3] | 6 |
| Report: “ <i>Concrete Pavement Joints</i> ” (1990) [4,5] | 6 |
| Report: “ <i>Aggregate Interlock: A Pure-Shear Load Transfer Mechanism</i> ” (1990) [4,6]..... | 6 |
| Report: “ <i>Control of Faulting Through Joint Load Transfer Design</i> ” (1990) [4,7]..... | 7 |
| Report: “ <i>Evaluation of the Subbase Drag Formula by Considering Realistic Subbase Friction Values</i> ” (1990) [4,8] | 7 |
| Report: “ <i>Feasibility of Class C FRP Load Transfer Devices for Highway Jointed Concrete Pavements</i> ” (1990) [4,9]..... | 7 |
| Report: “ <i>Design and Construction of Joints for Concrete Highways</i> ” (1991) [4,10] | 8 |
| Report: “ <i>Thermoset Composite Concrete Reinforcement Part 1 Final</i> ” (May 1992) [11] | 8 |
| Report: “ <i>Thermoset Composite Concrete Reinforcement Part 2 Final</i> ” (October 1992) [12]..... | 9 |
| Report: “ <i>Shear Response, Deformations, and Subgrade Stiffness of a Dowel Bar Embedded in Concrete</i> ” (November 1992) [13] | 11 |
| Report: “ <i>Non-Corrosive Tie Reinforcing and Dowel Bars for Highway Pavement Slabs</i> ” (November 1993) [1]..... | 12 |
| Report: “ <i>Evaluation of Pavement Joint Performance</i> ” (January 1994) [15] | 15 |
| Report: “ <i>Analysis Design, and Construction of Transverse Joint Load Transfer Systems For Rigid Pavements</i> ” (December 1994) [16]..... | 17 |
| Report: “ <i>Design, Construction, and Maintenance of PCC Pavement Joints</i> ” (1995) [4,17]..... | 17 |
| Report: “ <i>Coating Protection for Reinforcement: State of the Art Report</i> ” (1995) [4,18]..... | 17 |
| Report: “ <i>An Analysis of the Longitudinal Reinforcement in a Jointed Reinforced Concrete Pavement</i> ” (1995) [4,19] | 17 |
| Report: “ <i>Aging Degradation of Fiber Composite Reinforcements for Structural Concrete</i> ” (September 1995) [20]..... | 18 |
| Report: “ <i>Three-Dimensional Modeling of Rigid Pavement</i> ” (September 1995) [26] | 20 |
| Report: “ <i>Random Skewed Joints With and Without Dowels</i> ” (1996) [4,27] | 21 |
| Report: “ <i>Summary of Glass Fiber Reinforced Plastic Dowel Bar Research at</i> ” | |

| | |
|--|-----------|
| Iowa State University” (June 1996) [28] | 21 |
| Report: “Preliminary Assessment of the Potential Use of Alternative Materials for Concrete Highway Pavement Joints” (January 1997) [29]..... | 23 |
| Report: “Field Instrumentation of Dowels, Final Report” (May 1997) [30] | 26 |
| Report: “Load Transfer Design and Benefits for Portland Cement Concrete Pavements” (1997) [4,31] | 27 |
| Report: “Mechanistic Design and Analysis Procedure for Doweled Joints in Concrete Pavements” (1997) [4,32] | 28 |
| Report: “Prevention of Joint Faulting Based on Field Performance Modeling” (1997) [4,33] | 28 |
| Report: “FRP Dowels for Concrete Pavements” (May 1999) [34]..... | 28 |
| Report: “SHRP Joint Study: A Seven Year Look” (1999) [4,35]..... | 29 |
| Report: “Load-Deflection Behavior of Smooth Dowels” (November 1999) [36]30 | |
| Report: “Matching Load Transfer to Traffic Needs” (May 2000) [4,37]..... | 30 |
| Report: “Long Term Pavement Performance Findings Pay Off For Pennsylvania” (February, 2000) [4,38]..... | 31 |
| Report: “Glass Fiber-Reinforced Polymer Dowels for Concrete Pavements” (March 2001) [39] | 31 |
| Report: TR-408. “Investigation of Glass Fiber Composite Dowel Bars for Highway Pavement Slab.” (June 2001) [2]..... | 32 |
| Report: “Performance of Dowel Bars and Rigid Pavement, Final Report” (June 2001) [40] | 35 |
| Report: “Dowel Bar Optimization: Phases I and II” (July 2001) [41] | 36 |
| Report: “Fatigue behavior of glass fiber reinforced polymer dowels” (May 2001) [42] | 38 |
| Report: “Using the Minnesota Accelerated Loading Facility to Test Retrofit Dowel Load Transfer Systems” (2001) [43] | 40 |
| Current Running Alternative Dowel Bar Projects | 41 |
| Project: “Field Evaluation of Alternative Load Transfer Device Locations in Low Traffic Volume Pavements” (Started in July 1998) [44]..... | 41 |
| Project: “Identification of Critical Stress Concentration Around Dowel Bars” (Started in August 1998) [44]..... | 41 |
| Project: “Influence of Special Design Variables Upon Rigid Pavement Performance Regarding Contraction Joints” (Started in 1990) [44] | 42 |
| Project: “Seal Joints, Alternative Dowels” (Started in 1999) [44] | 43 |
| Project: “HITEC Test and Evaluation: Alternative Material Dowel Bars for Rigid Pavements – National Pooled Fund” (Started in 1999) [44] | 43 |
| Project: “Dowel Bar Retrofit of Rigid Pavements” (Started in 2000) [44]..... | 44 |
| Project: “Demonstration and Field Evaluation of Alternative Portland Cement Concrete Pavement Reinforcement Materials” (Started in June 2003) [44]..... | 44 |
| Project: “Field Evaluation of Elliptical Steel Dowel Performance” (Started in February 2002) [44]..... | 45 |
| STATE-OF-THE-ART (SOA)/THEORETICAL INVESTIGATION..... | 46 |
| Dowel Bar Load Distribution | 46 |
| Joint Effectiveness..... | 46 |
| Thickness Design | 47 |
| Dowel Bar Theory..... | 49 |

| | |
|--|-----------|
| <i>Introduction</i> | 49 |
| <i>Analytical Model</i> | 49 |
| <i>Modulus of Dowel Support</i> | 53 |
| <i>Load Transfer Across a Joint</i> | 54 |
| <i>Relative Deflection Between Adjacent Pavement Slabs</i> | 56 |
| <i>Bearing Stress</i> | 58 |
| GAPS IN KNOWLEDGE | 59 |
| Effects of moisture on fiber-reinforced polymer (FRP) dowels | 59 |
| Aging of fiber-reinforced polymer (FRP) dowels | 59 |
| Effects of road chemicals on FRP resin..... | 59 |
| Development of an FRP design procedure | 60 |
| Acceptable corrosion of steel dowel bars | 60 |
| Investigation of wheel load at pavement edge..... | 60 |
| Investigation of uneven dowel bar placement | 60 |
| Curvature of slab effects on dowel when load placed in middle of slab | 61 |
| Bearing and contact surface stresses for shapes other than circular | 61 |
| Modulus of dowel support, K_o , values for all shapes and sizes..... | 61 |
| Investigation of Load Transfer Efficiency of elliptical, circular, and other shaped dowels using different sizes and spacing..... | 62 |
| Further investigation of form factors (especially for shapes other than circles) | 62 |
| The relationship between $K_o b$ (modulus of foundation) versus $K_o y_o$ (bearing stress), needs to be determined for different shapes | 63 |
| Modifications of the AASHTO T253 test procedure are needed to identify the true inflection point of the dowel bar..... | 63 |
| Standardized testing procedures and ASTM Tests should be developed for dowel bars..... | 64 |
| Investigate the effects of oblonging of the hole for large number of cycles. | 64 |
| A universal procedure needs to be created so that any type of bar may be evaluated..... | 65 |
| Investigate criteria for large planes on runways and taxiways. | 65 |
| Investigate theory change for dowels used as expansion joints and larger joint widths. | 65 |
| A distinction between whether laboratory and field measurements are true needs to be made. | 65 |
| Need fatigue for a large number of cycles, (e.g. 10-60 million cycles for full-scale lab tests) and correlate with field cyclic results..... | 65 |
| RECOMMENDATIONS AND CONCLUSIONS..... | 66 |
| REFERENCES..... | 68 |

LIST OF FIGURES

| | |
|--|----|
| Figure 4.1 Load positions for critical stress..... | 48 |
| Figure 4.2 Semi-infinite beam on an elastic foundation..... | 50 |
| Figure 4.3 Slope and deflection of dowel at joint face | 51 |
| Figure 4.4 Forces acting on dowel..... | 52 |
| Figure 4.5 Load transfer distribution proposed by (a) Friberg and (b) Tabatabaie et al. | 55 |
| Figure 4.6 Relative deflection between adjacent pavement slabs | 57 |

INTRODUCTION

A vast majority of the nation's highways and roads are made of jointed concrete pavement. These joints allow for deformation and movement due to thermal and environmental conditions. Joints may either be longitudinal joints, parallel with traffic, or transverse joints, perpendicular to traffic. Transverse joints are placed at regular intervals creating discontinuities in the pavement and forming a series of slabs. Load transfer within a series of concrete slabs takes place across these joints. Therefore, an effective load transfer device must be present in order to transfer load between adjacent slabs.

For a typical concrete paved road, these joints are assumed to be approximately 1/8" gaps between two adjacent slabs. Dowel bars are located at these joints and used to transfer load from one slab to an adjacent slab. After a significant number of vehicles have passed over the joint, an **oblonging** where the dowel bar contacts the concrete can occur. This oblonging creates a void space, formed due to a stress concentration where the dowel contacts the concrete at the joint face directly above and below the dowel. Over time, traffic traveling over the joint crushes the concrete surrounding the dowel bar and causes a void in the concrete. This void inhibits the dowel's ability to effectively transfer load across the joint.

Possible corrosion of the dowel bar can potentially bind or lock the joint. When locking of the joint occurs, no thermal expansion is allowed and new cracks parallel to the joint are formed directly behind the dowel bars in the concrete. As temperature decreases, contraction of the concrete will occur resulting in the new cracks becoming wider and a resulting load transfer failure. Once there is no longer load transferred across the joint all the load is then transferred to the subgrade and differential settlement occurs in the adjacent slabs. Differential settlement of the slabs creates a vertical discontinuity at the joints, making vehicle travel uncomfortable and requiring that the slab be repaired or replaced.

A majority of the dowel bars used today for load transfer are epoxy-coated. This epoxy coating aids in the reduction of the exposure to corrosive agents. However, many times this coating is nicked or scraped before installation leaving the uncoated steel susceptible to deterioration.

As was mentioned previously, a void around a dowel bar is formed by stress concentrations crushing the concrete in direct contact with the dowel. When a wheel load is applied to the concrete slab, the force is supported only by the top or bottom of the dowel bar, not the sides. Since the stress concentration region lays on the top or bottom of the dowel bar, the smaller the dowel the higher the stress concentration. The sides of the dowel bar do not aid in the distribution of the wheel load from the concrete. Therefore, the stress concentration is located at the top and bottom of the dowel bar at the face of the joint and is directly related to the width and/or shape of the dowel bar. While round dowel bars handle these stress concentrations relatively well, other shapes and materials may provide a better distribution.

Researchers at Iowa State University (ISU) have been actively performing continuous research in the area of dowel bars for pavement slabs since 1991. Interest in this work was generated by the utilization of alternative dowel bar shapes and materials. A significant amount of research was funded by the Iowa Department of Transportation (Iowa DOT) in two fairly significant projects, resulting in several research reports, the most notable of which are Report HR343 “Non-Corrosive Tie Reinforcing and Dowel Bars For Highway Pavement Slabs” [1] and TR408 “Investigation of Glass Fiber Composite Dowel Bars For Highway Pavement Slabs” [2]. These reports serve as examples of the work done by Iowa State University. The concepts of alternative materials and shapes were to provide dowel bars that are not subject to the severity of corrosion and stress experienced by the current steel circular dowel bars.

Additional work has been done at ISU on a compilation of preliminary needs for dowel bars for highway pavement slab joints. A number of other reports have also been prepared for the Iowa Department of Transportation, American Highway Technology (AHT), Highway Innovative Technology Evaluation Center (HITEC) and others concerning dowel bar performance. In combining past and present knowledge, gaps found within dowel bar research can be closed and a universal test may be developed in order to properly evaluate dowel bars. These reports and others will be summarized and referenced in the background section of this report.

During the time that ISU has been conducting the Iowa DOT-sponsored work, other states have also begun to conduct additional studies on both laboratory specimens and field applications of alternative dowel bars. However, the various studies have not been coordinated amongst state or federal agencies. Therefore, apparent gaps in knowledge exist about what still needs to be researched and what areas of research may have been duplicated. The purpose of this project and report is to identify and summarize the identified gaps in the knowledge of dowel bars. In addition to the presentation of these gaps, this report will also provide a brief background of knowledge sources. The report is divided into six sections: Introduction, Objective and Scope, Background, Theoretical Investigation, Gaps in Knowledge, and Recommendations and Conclusions.

OBJECTIVE AND SCOPE

Objective

The objective of this “gap study” is to investigate the completed and ongoing research from across the nation to locate technology gaps and duplications in recent dowel bar research. A gap in dowel bar knowledge is any piece of information that is not already known that may pertain to the effectiveness of the dowel bar as a load transfer device.

Scope

The scope of this gap study included

- collecting research information conducted nationwide on dowel bars,
- determining the technology gaps and duplications in nationwide dowel bar research,
- contacting and questioning state and federal agencies active in dowel bar work,
- preparing a state-of-the-art (SOA) summary of current and ongoing research topics,
- preparing a final report showing a summary of the technology gaps of needed research.

BACKGROUND

In order to determine the technology gaps in dowel bar research, a collection of previous reports, studies and interviews were obtained so that each may be reviewed. From the review of this information, the technology gaps and duplications in dowel bar knowledge were determined. This section provides an annotated reference listing of the many sources from previous dowel bar research and, in several instances, objectives and significant conclusions for particular projects that were reviewed.

Much of this information was located and/or obtained through:

- database searches conducted by Mr. Theodore L. Neff of Peak Management Associates,
- telephone and e-mail interviews with individuals currently involved in dowel bar interests,
- library and database searches conducted by the authors.

This list is in no way considered a synthesis. Rather, its goal is to point out the holes or gaps pertaining to dowel bar research. It is intended to show the frequency with which the same research is being conducted and to point out research that needs to be done in order for dowel bar technology to advance.

Only reports and papers on dowel bar topics written since 1990 were included in this report. Most of these reports and papers contain similar references before the year 1990. Therefore, it is the author's decision to review only the history of dowel bar reports occurring over the past 13 years. Between these reports, the entire history of dowel bar research is contained.

The following reports and papers are listed in chronological order, starting with the older reports. Projects currently underway are listed at the end. Some of these projects either have no report or a report has not yet been written; however, a project description is still included.

Previous Dowel Bar Projects and Reports

Report: “The Design of Plain Doweled Jointed Concrete Pavement” (April 1989) [3]

As stated in this report,

The main objectives of this report are to summarize the findings of past reports, to communicate the experiences of the various states and foreign countries, and to emphasize the need for dowels as a positive method of load transfer on most, if not all, medium and heavy truck traffic routes with plain jointed concrete pavements. Of the three basic types of concrete pavements—jointed plain concrete pavement (JPCP-doweled or undoweled), jointed reinforced concrete pavement (JRCP), and continuously reinforced concrete pavement (CRCP), this report will concentrate on the transverse joint design for JPCP. However, much of the information would apply to doweled joints in JRCP also. [3]

Report: “Concrete Pavement Joints” (1990) [4,5]

As stated in reference [4],

This technical advisory provides guidance and recommendations relating to the design and construction of joints in conventional portland cement concrete (PCC) pavements. The various joint types found in PCC pavement are defined and then guidelines and recommendations on their use, design, and construction are presented. Information on transverse contraction joints (spacing, load transfer, joint reservoir design), construction joints (transverse and longitudinal), longitudinal contraction joints, and expansion joints is provided. [4]

Report: “Aggregate Interlock: A Pure-Shear Load Transfer Mechanism” (1990) [4,6]

As stated in reference [4],

A finite element investigation was made of the behavior of jointed or cracked pavement systems equipped with a pure-shear load transfer mechanism, such as aggregate interlock. Dimensional analysis was used in the interpretation of the data, leading to a general definition of the relative joint stiffness of the pavement system in terms of its structural characteristics. Results obtained in this study were verified by comparisons with earlier published field, laboratory, and analytical information. The investigation demonstrated that deflection load transfer efficiency is related to stress load transfer efficiency and that this relationship is sensitive to the size of the applied load (or to the gear configuration). A simple back-calculation procedure is outlined to evaluate the in-situ joint stiffness of such pavements. Pure-shear load transfer devices are shown to be particularly desirable under a combined externally applied and thermal loading condition, since they offer no additional restraint to longitudinal curling. [4]

Report: “Control of Faulting Through Joint Load Transfer Design” (1990) [4,7]

As stated in reference [4],

This paper describes and evaluates the development of mechanistic-empirical algorithms for more realistic estimates of anticipated faulting in concrete pavements. Earlier theoretical investigations are considered, interpreted through more recent finite element analysis results, and calibrated using an extensive database of field observations. One factor influencing faulting is the dowel-concrete bearing stress, for which an improved method of determination is presented. A procedure is outlined for assessing the need for dowels in both plain and jointed reinforced concrete pavements and determining the bar diameter needed to prevent significant faulting. Application of the procedure is facilitated through use of the program, PFAULT, which can be implemented on a personal computer. [4]

Report: “Evaluation of the Subbase Drag Formula by Considering Realistic Subbase Friction Values” (1990) [4,8]

As stated in reference [4],

A modification of the reinforcement formula that considers the realistic frictional characteristics of subbase types is presented. The objective of this study is not to abandon the current formula but to arrive at a better formula, one that considers the field observations. Rational reinforcement design is important because the amount of reinforcement affects the restraint on the movement of a pavement section, or slab, and the long-term performance. The reinforcement formula was modified in accordance with the experimental results obtained concerning subbase frictional resistance. The new formula represents the actual components of frictional resistance at the interface: adhesion, bearing, and shear. The formula calculates the steel requirement for the middle of the slab; in other words, the calculated value is the maximum requirement, and the locations between the free end and the middle of the slab will require less reinforcement. Further experimental study is necessary to calibrate the new formula. [4]

Report: “Feasibility of Class C FRP Load Transfer Devices for Highway Jointed Concrete Pavements” (1990) [4,9]

As stated in reference [4],

The objective of this paper is to analyze the feasibility of using corrosion free fiberglass reinforced plastic (FRP) devices in lieu of steel tie bars in the longitudinal joints of highway concrete pavements. The FRP devices are designed to provide the same shear transfer capability as the currently used steel tie bars. FRP devices consisting of bars, channel and I-beam shapes are considered. It is found that on terms of cross sectional area, the amount required for FRP devices is greater than that for steel bars. This is due to the fact that the modulus of elasticity of the FRP is lower than that of steel. In terms of cost of materials, it is found that FRP devices are more expensive than steel tie bars. However, prevention of deterioration due to corrosion may extend the service life of the

joints and therefore that of the pavement. More research is needed to accurately define the increase of service life when corrosion is prevented. [4]

Report: "Design and Construction of Joints for Concrete Highways" (1991) [4,10]

As stated in reference [4],

This publication addresses the design and construction of joint systems for concrete highway pavements (which typically range in thickness from 8 to 14 inches). The need for joints in concrete pavements is first discussed, including a description of the mechanisms of natural crack development due to thermal and shrinkage stresses. The various types of joints are described, and special emphasis is placed on the design of transverse joints, including recommendations for spacing, skewing, load transfer, and construction (dowel placement, sawing, sealing). The design and construction of other joint types (construction joints, expansion joints, longitudinal joints) are also described. [4]

Report: "Thermoset Composite Concrete Reinforcement Part 1 Final" (May 1992) [11]

This is Part 1 of a two-part report. Part 1 contains a comparison of unaged fiber composite and steel dowels and derivation of the appropriate theoretical model for analyzing the results.

Part 2 covers the theoretical and experimental models for accelerated aging of fiber composite reinforcing bars and dowels cast in a concrete environment and is the next report discussed.

As stated in this report,

The objectives of this study were

- to determine shear behavior and strength of FC dowel bars without aging,
- to determine shear behavior and strength of FC dowel bars with aging,
- to determine potential aging effects on bond of FC reinforcing bars.

The scope of this study included

- selecting an appropriate theoretical model for analyzing the results,
- designing and constructing of experimental tests for objectives 1 and 2,
- testing the dowel-shear specimens both aged and unaged,
- analyzing the dowel shear testing results,
- designing and constructing the test specimen details for examining the aging effects on bond behavior of FC reinforcing bars in concrete,
- conducting experiments and analyzing results for FC reinforcing bars.

Conclusions made from this project report are the following:

- Different theoretical models for the analysis of dowels were investigated and

developed. Timoshenko's analysis was concluded to be the most appropriate method. A solution to the finite beam problem, as opposed to the conventional semi-infinite solution was considered. A comparison between the results obtained from the analysis using the developed theoretical model and the results obtained using the semi-infinite idealization was made.

- The experimental investigation yielded results establishing maximum strengths, behavioral characteristics and failure modes. The maximum strengths were based upon a reasonably expected elastic load (REEL). The average value of REEL observed for the FC dowel specimens was 13,849 lbs compared with a typical required maximum service load of 4,500 lbs. The maximum bending moment in the FC dowel was observed to be 7,000 lb-in resulting in a fiber stress value of 56,506 psi which is less than the ultimate coupon flexural stress of 100,000 psi. [11]

Report: "Thermoset Composite Concrete Reinforcement Part 2 Final" (October 1992) [12]

This is Part 2 of a two-part report. Part 1 contained a comparison of unaged fiber composite and steel dowels and derivation of the appropriate theoretical model for analyzing the results.

Part 2 covers the theoretical and experimental models for accelerated aging of fiber composite reinforcing bars and dowels cast in a concrete environment.

As stated in this report,

The objectives of this study were

- to determine shear behavior and strength of FC dowel bars without aging,
- to determine shear behavior and strength of FC dowel bars with aging,
- to determine potential aging effects on bond of FC reinforcing bars.

The scope of this study included

- selecting an appropriate theoretical model for analyzing the results,
- design and construction of experimental tests for objectives 1 and 2,
- testing the dowel-shear specimens both aged and unaged,
- analyzing the dowel shear testing results,
- designing and constructing the test specimen details for examining the aging effects on bond behavior of FC reinforcing bars in concrete,
- conducting experiments and analyzing results for FC reinforcing bars.

Conclusions made from this project report:

Accelerated aging. A very good approximate model was developed for accelerated aging of FC materials that will approximate real weather aging. Two equations were developed for accelerated aging in central Iowa (Ames). The following equation relates the temperature of the aging bath to the number of days aged per day.

$$\text{Age} * (\text{days/day}) = 0.200 e^{0.052 * T}$$

The next equation, the acceleration factor (AF) equation adjusts the number of days aged per day to account for a mean annual temperature (MAT), that is different than the United Kingdom (UK) where the accelerated aging process was developed.

$$\text{AF} = 2.986 \text{ E-}19 e^{13.783X}$$

The E-glass fibers encapsulated in a vinyl ester resin matrix have proven in this research to be very resistant to accelerated aging effects.

Pullout Specimens. A theoretical model was developed to approximate the mechanical bond degradation in the pullout specimens. Using the following equation, the tensile elongation could be approximated using a varying length L_b , that took into account the mechanical bond failure.

$$\delta = (P_t * L_b) / (E * A_{FC})$$

Dowel Specimens. Overall, the accelerated aging solutions of water, lime and salt apparently had little or no affect on the shear strength behavior of any of the dowel bars.

Approximate equations were developed for FC and steel dowels and accounted for both concrete splitting and concrete bearing type failure modes. These equations were developed for unaged dowel specimens and approximated the dowel specimens' failure very close. For a 1.25 in. diameter FC dowel cast in a 10 in. thick concrete specimen the equation is:

$$P_d = 1.68 f'_c$$

For a 1.50 in, diameter steel dowel cast in a 10 in, thick concrete specimen the equation is:

$$P_d = 3.00 f'_c$$

Verification was made on the testing procedure (clamping method) for the dowel specimens. The authors determined that it was a representative testing procedure based upon the Iosipescu shear test. The clamping method was modified to more closely represent the Iosipescu shear test. Upon doing so, the REEL loads, deflections, and failure modes were very consistent between the two testing procedures.

The steel dowel bars in the dowel-shear specimens were strain gauged to check the theoretical moment distribution along the dowel bar as presented in Part 1 of this report. An experimental moment distribution was developed based upon the strain gauged dowel specimens. The theoretical moment distribution was approximately equal to the experimental moment distribution. An inflection point was not observed in the experimental moment distribution. Overall the author's

feel that the theoretical model developed in Part 1 is representative of the steel dowel specimens and is also representative of the FC dowel specimens. [12]

Report: "Shear Response, Deformations, and Subgrade Stiffness of a Dowel Bar Embedded in Concrete" (November 1992) [13]

As stated in this report,

This study has four different but closely allied objectives concerning the modelization and behavior of dowel action in a reinforcing bar in relation to the following topics:

- the subgrade stiffness formulation of the concrete embedment,
- the reliability of a few equations proposed in the literature for the evaluation of the dowel strength, including also a few cases which have particular relevance (high-strength concrete and inclined dowels),
- the actual displacement field of a dowel bar embedded in the concrete,
- the formulation of a plastic hinge in the dowel bar and a flake in the concrete underneath, and the evaluation of the length of the plasticized zone along the dowel bar.

Conclusions:

Tests from block-type specimens, reinforced with a single long dowel acting against the concrete core and with the shear plane coincident with specimen forefront, show that:

- The behavior of a long dowel is mostly elastic (both in the bar and the embedment) for shear forces not exceeding 40 percent of the ultimate capacity: such behavior is definitely confirmed by the actual, measured displacements and the ensuing curvature distributions.
- At collapse, more than 50% of the dowel section is plasticized over a bar length close to two diameters, with a peak at 1 diameter from the shear plane; as regards concrete, a flake gets detached underneath the dowel, at 75 percent of the ultimate load, with a depth close to 0.4 to 0.6 bar diameters from the shear plane.
- The load-displacement curves are mostly elasto-plastic in the case of the normal concrete, with natural rounded aggregate, but tend to be elasto-softening in the case of high-strength concrete, with basaltic, crushed aggregates.
- As a rule, the equations found in the literature for the evaluation of ultimate dowel capacity are reliable for normal concrete, both for dowels at right angles to the shear plane and for inclined dowels or slanted shear planes; to a lesser extent, the same equations are still valid for high-strength concrete. These equations are

$$V_u = V_{\max} * \sqrt{30/f'c} \text{ for normal concrete}$$

$$V_u = V_{\max} * \sqrt{75/f'c} \text{ for high-strength concrete}$$

- Modeling the dowel as an “equivalent” elastic beam resting on a cohesionless soil can still provide a realistic description of the nonlinear response of the loaded section, on condition that the subgrade stiffness is formulated as a function of the “damage” accumulated in the concrete embedment and in the dowel bar: this damage may be represented by means of a suitable “damage index”.
- The proposed formulations for the subgrade stiffness of the concrete embedment cannot describe the entire distribution of the displacements along the interface (i.e., along dowel axis): with regard to this point, more refined formulations for the subgrade stiffness should be introduced, together with a better modelization of the bar (an elasto-plastic constitutive law for the steel should be sufficient). [13]

Report: "Non-Corrosive Tie Reinforcing and Dowel Bars for Highway Pavement Slabs"
(November 1993) [1]

As stated in the project report,

The objectives of this study were

- to develop a laboratory test method for the evaluation of highway pavement dowels which approximates actual field conditions,
- to compare static, fatigue, and dynamic behavior of fiber composite (FC) dowels to those for steel dowels when used as load transfer devices in transverse joints of highway pavements,
- to study the bond characteristics of the fiber composite tie rod.

The scope of this study included

- an evaluation of previous testing performed on pavement dowels and an extensive review of literature dealing with pavement dowels and fiber composite materials,
- placement of FC dowels and FC tie rods in an actual highway pavement during new construction,
- development of a program for monitoring and evaluating the performance of FC dowels placed in an actual pavement,
- monitoring and evaluation of the performance of FC dowels placed in an actual pavement,
- computer modeling and analysis of an actual highway pavement joint system and a laboratory full-scale pavement joint system in order to design a laboratory testing setup,
- design and construction of experimental test setups and specimens for static,

fatigue, and dynamic testing of FC and steel dowels, and static bond tests on FC tie rods,

- testing of elemental dowel specimens under static loading,
- testing of full-scale slab specimens which use FC and steel dowels, and full-scale beams with FC tie rods, and
- analyzing results of tests on full-scale pavement slabs, elemental dowel specimens, and on FC tie rod beams.

Conclusions made from this project report:

Overall conclusions:

- The joints utilizing FC dowels studied in this report performed as well as joints utilizing standard steel dowels when both were subjected to conditions which simulated actual highway pavement use, including cyclic loading.
- The laboratory test methods for evaluation of highway pavement dowel bars, which were developed during this research (i.e. the elemental modified iosipescu and the full-scale slab), provided good behavioral results for highway pavement joint conditions.
- The full-scale pavement testing procedures applied in this research provided a good method for monitoring and evaluating the behavior of dowel bars when placed in a concrete pavement joint subjected to cyclic loading.

Conclusions specifically related to the full-scale slab testing:

- The 1.75-in. FC dowels spaced at eight inches performed at least as well as 1.5-in. steel dowels at 12 inches in transferring static loads across the joint in the full-scale pavement test specimens. The performance of the 1.75-in. FC dowels spaced at 12 inches was similar to that of the 1.5-in. steel dowels spaced at 12 inches with any difference being attributed to dowel diameter.
- The load transfer efficiency of 1.75-in. FC dowels spaced at eight inches in a full-scale pavement slab was nearly constant (approximately 44.5% load transfer) through two million applied load cycles with a maximum of 9,000 pounds.
- The load transfer efficiency of 1.5-in. steel dowels spaced at 12 inches in a full-scale pavement slab decreased (approximately from 43.5% to 41.0% load transfer) over the first two million cycles.
- The load transfer efficiency of 1.75-inch FC dowels spaced at 12 inches in a full-scale pavement slab decreased from an initial value of approximately 44% to a final value of approximately 41% after 10 million cycles.

- Load transfer by 1.5-in. steel dowels spaced at 12 inches in a full-scale pavement slab remained rather constant (approximately 41.0%) beyond two million cycles through ten million load cycles.
- The behavior of increasing relative displacements at a pavement joint, due to a 9,000-pound load, as the number of load cycles increased occurred for both the FC and steel dowels studied in this research.
- Relative displacements measured at pavement joints with 1.75-in. FC dowels spaced at eight inches were slightly smaller than at joints with 1.5-in. steel dowels spaced at 12 inches. Both were subjected to similar load and support conditions during the testing.
- Load transfer by individual FC and steel dowels in a full-scale pavement joint can be determined by relating the measured dowel strains to the strains measured during elemental testing of the same types of dowels.
- The use of steel beams as simulated subgrade in place of soil subgrade was effective for the study of pavement dowel performance under fatigue and static loading.
- The test procedure developed and applied in the full-scale pavement slab testing provided results which were valuable in performing an analysis of dowel behavior.
- Using hydraulic actuators to simulate truck traffic in laboratory testing of full-scale pavement joints was effective for the evaluation of dowel behavior at the joints.

Conclusions specifically related to the elemental specimen testing:

- Elemental specimen testing, by examining the performance of a single dowel in shear, was valuable in support of full-scale pavement testing.
- The behavior under static loading of FC dowels during elemental shear testing was similar to their behavior during full-scale slab specimen testing.
- Results from previous testing of steel dowels in elemental specimens [14] and results from full-scale testing in this study indicated that steel dowels behaved similarly during full-scale and elemental static testing.
- The modified Iosipescu shear test procedure for elemental dowel testing provided an adequate method for evaluating the shear properties of a pavement dowel/concrete system.

- Values of the modulus of dowel support, K_o , for dowels tested in elemental shear specimens with equal concrete strengths were directly related to the flexural rigidity of the dowels.
- Values of K_o for 1.75-in. FC dowels were determined to be 358,000 and 247,000 pci for elemental specimens with concrete compressive strengths, $f'c$, of 7,090 and 5,092 psi, respectively. These values compare to those determined in reference [14] $K_o = 650,000$ pci for 1.5-in. steel dowels in concrete with $f'c = 7,090$ psi.
- Steel shear reinforcing was not required in elemental specimens for the evaluation of the performance of highway pavement dowels under service level loads.

Conclusions specifically related to field testing of FC dowels in actual highway pavement joints:

- Evaluation using the Road Rater™ testing machine indicated that the performance of FC dowels in two test joints was equivalent to that of steel dowels in four adjacent joints. Average relative displacements were measured at the outside wheel track to be 0.035 and 0.03 mils for the joints with FC and steel dowels, respectively, and 0.05 mils at the inside wheel track for both types of joints.
- No difference in joint performance was observed during visual inspections of pavement joints with FC dowels and adjacent joints with steel dowels.
- The FC dowels placed in two test joints allowed the pavement to crack at the joint locations.
- During very cold weather, the FC dowels in the test joints functioned properly by allowing the pavement to contract and the joint opening to increase. [1]

Report: "Evaluation of Pavement Joint Performance" (January 1994) [15]

As stated in this report,

The objectives/scope of this study were

- to examine the load transfer mechanism under traffic loading,
- to modify an existing finite element program to properly simulate the response of undercut contraction (YU) and contraction (Y) joints,
- to compare field data with results predicted by the finite element program,
- to recommend improvements in the design procedure of joints with emphasis on minimizing cost and construction time.

Conclusions made from this project report:

Based on the results of the field study and finite element analysis, the following conclusions can be drawn:

- The two dominating forces in the dowel bar are moment around the X-axis and the shear force. The moment about the Y-axis, axial force and torque do not make a significant contribution to the response of the dowel bar.
- Stiffness of the subgrade has a significant influence on the response of the dowel bar.
- The looseness of the dowel bar affects the response of the dowel. If the hole is larger than the dowel bar, the load transfer is not sufficient.
- Based on observations at the site and evaluation of the data, the 1 in. diameter fiberglass dowel is not recommended for rigid pavement.
- The larger diameter and stiffer bars transfer more load across the joint.
- The most efficient dowel for load transfer is the 1.5 in. diameter steel bar.
- The finite element model (ILLI-SLAB) is not capable of predicting true response of the joints.
- Stresses are small in concrete for bending and also dowel bearing.
- The presence of the undercut in a joint initially reduces the forces in the dowel bar; however, after a short period of time, the effectiveness of the undercut diminishes.
- Despite the type of joints (Y or YU), after several months the magnitude of forces in the dowel bars approaches the same range.
- In rigid pavement, shear forces, due to truck speeds from 45 to 65 mph, are similar, however, at speeds less than 30 mph shear forces increase.
- Measured dowel forces are smaller than values predicted by analytical and theoretical methods.
- The performance of a 1.5-inch diameter fiberglass dowel bar approached that of a 1.0 in. diameter steel dowel. [15]

Report: “Analysis Design, and Construction of Transverse Joint Load Transfer Systems For Rigid Pavements” (December 1994) [16]

As stated in the project report abstract,

This report discusses...the evolutionary developments in mechanistic dowel behavior theory proposed by Bradbury, Grinter, Friberg, Lessels, Timoshenko, and Westergaard (in chronological order). New findings relating to dowel bar behavior obtained from finite element modeling are discussed. A sampling of pavement performance models which use empirical or empirical-mechanistic statistical regressions to estimate load transfer performance (expressed as transverse joint faulting) in terms of material, environmental and from a limited number of field performance and laboratory studies are summarized. Seventy years of design recommendations as inferred from theoretical developments, field performance observations and laboratory studies are reviewed. Recommended construction and transverse joint/load transfer restoration are presented. Joint related rigid pavement distresses are described. Finally, limited information concerning a proposed new load transfer system (X-FLEX™) under development at Kansas State University is presented. [16]

Report: “Design, Construction, and Maintenance of PCC Pavement Joints” (1995) [4,17]

As stated in reference [4],

Portland cement concrete (PCC) pavements require joints to control the natural cracking associated with shrinkage caused by drying and with movements caused by changes in temperature and moisture conditions. This report records the state of the practice with respect to the design, construction, and maintenance of PCC pavement joints. An overview of concrete pavement jointing is presented, including a description of current practices used by highway agencies. This is followed by general joint design considerations, such as load transfer needs, joint spacing requirements, and joint reservoir and sealant design. A discussion on current joint construction practices and quality control considerations is also provided to illustrate critical construction requirements, and a summary of recommended joint repair and maintenance practices is presented. [17]

Report: “Coating Protection for Reinforcement: State of the Art Report” (1995) [4,18]

As stated in reference [4],

This expert report provides a comprehensive survey of hot-dip galvanizing and epoxy-or-PVC-coating protection systems for steel reinforcement. It examines influences on materials and application in manufacturing, performance in concrete environments, and practical experience. It also offers guidance on the choice of protection systems. [18]

Report: “An Analysis of the Longitudinal Reinforcement in a Jointed Reinforced Concrete Pavement” (1995) [4,19]

As stated in reference [4],

The longitudinal steel in many jointed reinforced concrete pavements (JRCP) designed using current procedures has failed prematurely, resulting in excessive crack widths, spalling, faulting, loss of subgrade support, and so on. A review of current

procedures shows that only extensional tensile stresses are now considered in design. A new design procedure must be developed that will consider all sources of stress and thereby prevent premature failure. [19]

Report: "Aging Degradation of Fiber Composite Reinforcements for Structural Concrete" (September 1995) [20]

As stated in this project report,

The objectives of this study were

- to overall, test long-term durability of commercially available FRP products for reinforcement of structural concrete,
- to evaluate the structural behavior and tensile strength of unaged commercially available FRP rebars and prestressing tendons,
- to evaluate the structural behavior and tensile strength of commercially available FRP rebars and prestressing tendons directly exposed to an accelerated aging solution,
- to determine the potential effect of corrosion or simulated aging on FRP rebars under constant load,
- and to investigate the potential effect of corrosion or simulated aging action on prestress losses in concrete beams reinforced with FRP prestressing tendons.

The scope of this study was

- to obtain FRP reinforcement for prestressed and non-prestressed concrete applications which are available from domestic and/or international suppliers,
- to develop loading jigs to maintain FRP rebar specimens under constant load, a prestressing frame, aging tank, and an aging bath management system,
- to develop a gripping technique suitable for tensile testing of the FRP rebar specimens investigated in this study. Perform tensile testing of unaged FRP rebar and prestressing tendon specimens,
- to construct FRP prestressed beam specimens, using the prescribed prestress level specified by the sponsor,
- to study the effect of potential cracking of the resin by preloading FRP rebars prior to submerging the specimens in the aging solution,
- to develop an accelerated aging technique for the specimens submerged in a high alkalinity aqueous solution at an elevated temperature, expanding on the

experimental technique developed by the Pilkington Bros. Ltd. [21-25] and also based on previous accelerated aging research at Iowa State University [12,14],

- to study the effect of the corrosion or simulated aging on the ultimate tensile strength and other properties of the FRP rebars and prestressing tendons,
- to perform flexural testing on aged and unaged prestressed concrete beams. And to perform flexural testing on beams cast after the aging period with the aged and unaged FRP rebar reinforcement.

Conclusions made from this project report (GFRP rebars):

- The unaged GFRP rebars exhibited lower ultimate tensile strengths than expected. The test results were consistent with average results as low as 50-55 ksi (345-379 Mpa). This average was approximately 50% of the ultimate tensile strength specified by the manufacturers for these specimens. Based on the consistent results and the evaluation of the tensile failures the test results were found to be valid and not influenced by the grips.
- The tensile test results of unaged GFRP rebars obtained at ISU were verified by Dr. Dolan at the University of Wyoming (UW). Additional GFRP rebar specimens were gripped and tested by Dr. Dolan, using a gripping technique developed at UW, and compared to the specimens tested at ISU using the gripping technique developed at ISU. The fact that the tensile test results from UW were in the same range as the results obtained at ISU verified the test procedure used in this study. The tensile test results obtained at ISU were therefore concluded to be valid.
- The tensile test results of the unaged and aged GFRP rebars were also verified in flexural testing of concrete beams, containing either unaged or aged GFRP rebar reinforcement. These test results showed that the lower than expected ultimate tensile strengths obtained for the unaged and aged GFRP rebar specimens were not influenced by the test procedure or the gripping technique used in this study.
- Compared to the unaged specimen properties, the ultimate tensile strength was greatly reduced after 19 days of accelerated aging, which was equivalent to approximately 5.4 years of real time aging. The study, therefore, showed that the direct exposure to the highly alkaline solution could rapidly reduce the ultimate tensile strength of the GFRP rebars.
- Rebar specimens exposed to accelerated aging equivalent to approximately 50 years of real time aging exhibited reduced ultimate tensile strength and maximum strain capacity. The modulus of elasticity was not affected by the accelerated aging. The study showed that accelerated aging in a highly alkaline environment significantly reduces both the ultimate tensile strength and the maximum strain capacity of directly exposed GFRP rebar specimens. Furthermore, the comparison between the ultimate tensile strength after 19 and 81 days of accelerated aging

showed that the strength losses were not a linear function of the number of days aged.

- Sustained loading at 40% of ultimate tensile strength of unaged GFRP rebars for almost three months did not affect the ultimate tensile strength or the modulus of elasticity of the rebars. However, the results from the final tensile testing indicated that the sustained loading reduced the maximum strain capacity slightly.
- The combination of sustained loading at 40% of ultimate tensile strength and of exposure to the aggressive environment from the aging solution significantly affected the ultimate tensile strength and the maximum strain capacity of the GFRP rebars. Several specimens failed after only a few days of exposure to the aging solution.
- Preloading specimens to 40% of the ultimate tensile strength for a few minutes followed by a release of stress prior to aging had no apparent effect on the GFRP rebars. After aging these specimens to an equivalent of approximately 50 years, the tensile test results were virtually identical to the results obtained for the aged specimens. Thus, the 40% stress preload and release did not appear to be causing instant cracking of the resin.
- The light microscope investigation verified the tensile test results. The images clearly showed that exposure to the aging solution had caused extensive corrosion of the protective resin seal on the outer surface of the GFRP rebar specimens. [20]

Report: "Three-Dimensional Modeling of Rigid Pavement" (September 1995) [26]

The objectives/scope of this study as stated in the report were

To develop a finite-element program to model the response of rigid pavement to both static loads and temperature changes. The program is fully three-dimensional and incorporates not only the common twenty-node brick element but also a thin interface element and a three-node beam element. The interface element is used in the pavement-soil interface and in the joints between slabs. The dowel bars in the joints are modeled by the beam element, which includes flexural and shear deformations. Stresses, strains, and displacements are computed for body forces, traffic loads, and temperature changes individually so that the program can be used to obtain either total stresses for design, or strain changes to compare with experimental data.

The effects of varying the material properties in the pavement, base, subgrade, interface, and dowels are investigated to identify those parameters which most influence the solution. Results of various interface thickness and dowel diameters also are presented. A further study is conducted to determine the effect of average pavement temperature on the curling stresses and displacements.

Conclusions made from this project report:

- The finite element program used in this study has proved to be capable of predicting accurately the displacements of a rigid pavement slab under a thermal gradient loading.
- Predicted stresses have differed from experimental data by a greater margin, but they have been in at least reasonable agreement. Better results probably could be obtained by extending the program to model nonlinear concrete behavior, pavement cracking, and steel reinforcement. [26]

Report: “Random Skewed Joints With and Without Dowels” (1996) [4,27]

As stated in reference [4],

The objective of this study was to compare the performance of a nonreinforced concrete pavement with random spaced, skewed dowel bars versus one without dowel bars. The conclusions from this project are as follows:

- The doweled pavement continues to perform better than the non-doweled pavement
- The life of the doweled pavement is estimated to last approximately 2.5 times longer than the non-doweled pavement prior to any maintenance or rehabilitation
- The epoxy coated dowel bars in the test section remained intact (i.e., no corrosion)
- The use of dowel bars increases initial concrete pavement cost by approximately 7.8%
- Over a 25-year service life, a non-doweled pavement would cost approximately 13.1% more than a doweled pavement
- The use of dowel bars in concrete pavement currently saves the Wisconsin Department of Transportation approximately \$6,000,000 per year, and
- The employment of dowel bars is a cost effective method of extending the service lives of concrete pavements while enhancing the pavement performance and reducing user inconvenience. [4]

Report: “Summary of Glass Fiber Reinforced Plastic Dowel Bar Research at Iowa State University” (June 1996) [28]

As stated in this report,

The content of this paper is constrained to research conducted on GFRP and steel pavement dowels at the ISU Structural Laboratory through the auspices of the Engineering Research Institute. Material included in this paper was adapted from research projects sponsored by the Highway Division of the Iowa Department of

Transportation (DOT) and the Iowa Highway Research Board. Additional summaries and reference listings of research findings on related topics in construction oriented fiber composites are also included. The information contained on some of the references is not available to the general public without prior approval.

In this paper each section is a self-contained unit including the full experiment setup, results, and conclusions for its specific objectives.

The scope of these sections includes

- The investigation of the feasibility of substituting GFRP (thermoset) pavement dowels for steel pavement dowels. Examined is the load transfer capacity, flexural capacity, and material properties for unaged GFRP dowel bars. A theoretical model is developed which includes the effects of modulus of elasticity for the pavement dowels and concrete, dowel diameter, subgrade stiffness, and concrete compressive strength.
- An experimental investigation that is carried out to establish the modulus of dowel support which is an important parameter for the analysis of dowels. The experimental investigation includes measured deflections, observed behavioral characteristics, and failure mode observations. An extensive study is performed on various shear-testing procedures. A modified Iosipescu shear method is selected for the test procedure. Also, a special test frame is designed and fabricated for this procedure.
- The experimental values of modulus of support for shear and GFRP dowels are used for arriving at the critical stresses and deflections for the theoretical model developed. Different theoretical methods based on analyses suggested by Timoshenko, Friberg, Bradbury, and Westergaard are studied in the development of the theoretical model.
- Focus on the effects of accelerated aging on fiber composite reinforcing bars and dowel bars composed of E-glass fibers encapsulated in a vinyl ester resin matrix. These fiber composite specimens are cast in concrete and exposed to three different aging bath solutions (water, lime and salt) at an elevated temperature of 140°F for nine weeks. Control (unaged) specimens are compared with aged specimens, and the affects of aging are then observed. The aged fiber composite dowel bars in concrete specimens are tested in direct shear to find the effects of accelerated aging on the shear capacity.
- “Real-World” testing of GFRP dowel bars compared to steel dowel bars is investigated. GFRP dowel bars are placed at two transverse joints during construction of a new concrete highway pavement, as are steel dowel bars, in order to evaluate their performance under actual field conditions.
- Fatigue, static, and dynamic testing is performed on full-scale concrete pavement slabs which are supported by a simulated subgrade and which include a single transverse joint. The behavior of the full-scale specimens with both steel and

GFRP dowels placed in the test joints are monitored during several million-load cycles which simulate truck traffic at a transverse joint.

- A discussion of related fiber composite research projects performed at the Iowa State University Structural Laboratory. Several projects dealt with structural testing of fiber composites as the primary tensile load carrying members in concrete. Other projects consisted of testing fiber composite sandwich wall connectors. [28]

Report: "Preliminary Assessment of the Potential Use of Alternative Materials for Concrete Highway Pavement Joints" (January 1997) [29]

As stated in this report,

The objectives of this study were

- To identify background information on the use of load-transfer devices in highway pavement joints and to provide a preliminary assessment of the market for the use of alternative materials in that capacity.
- To provide a concise compilation of information upon which the Highway Innovative Technology Evaluation Center (HITEC) personnel may judge whether or not the use of alternative materials for concrete highway pavement joints is worth a more thorough and rigorous evaluation.

The scope of this study included

- A compilation of information provided by state organizations in the form of responses to the HITEC survey.
- A brief overview of topics deemed vital by HITEC personnel to the evaluation of alternative material for concrete highway pavement joints. The contained information is the result of an extensive search of highway literature and expert knowledge.
- Recent findings of research investigations and field applications (up to 1997) of alternative load-transfer devices are discussed to provide the most recent evaluations of performance of some of the currently available alternative products.
- Qualitative analysis of the information and should be treated as the first step in the complete evaluation of the use of alternative materials in concrete highway pavement joints. No attempt was made to perform a rigorous statistical analysis of the survey information, nor was an "in-depth" assessment of the dowel market undertaken."

Conclusions made from this project report:

Conclusions resulting from the 1997 HITEC Survey:

- The six states most interested in alternative material dowels are New York, Kansas, West Virginia, Ohio, Iowa, and North Dakota.
- Circular, epoxy-coated carbon steel bars predominate the existing use of load-transfer devices.
- The most common reported problems with load-transfer devices are placement/misalignment of the dowels during construction and “seizing” of the dowels due to corrosion during the service life of the pavement.
- Strength and corrosion resistance appear to be the most important performance characteristics of a joint system according to state organizations.
- A majority of the state organizations are either unsure of their financial commitment or would pay little or no more of a first-cost premium over their present systems for alternative materials.
- 40% of the responders indicated they had considered alternative materials, with the majority (79%) considering fiber composites.
- Although many field applications of alternative material dowel bars have been implemented (9 states), the long-term performance of the new materials is too soon to be evaluated.
- 86% of the state organizations would consider alternative materials given certain criteria are met, the most important being long-term demonstration project data.
- Interest in future HITEC activities related to the use of alternative materials appears to be quite high with 14 of the state organizations indicating interest in serving on a panel and 11 indicating interest in providing locations for field demonstrations.

Conclusions resulting from HITEC Major Topic Review:

- Jointed rigid pavements represent most ($\geq 90\%$) of the rigid pavements in the United States.
- The estimated total mileage of jointed rigid pavements in the current United States highway system is 115,404 miles.
- The estimated amount of doweled PCC paving in the United States is 40,850,000 square yards per year.

- The estimated quantity of required dowels for the United States is 18,500,000 dowels per year.
- The states of Alaska, Massachusetts, Montana, New Hampshire, New Mexico, and Vermont specify no significant amount of PCC pavement, and are therefore potentially poor markets for alternative material dowels.
- The states of Texas, Oregon, Maryland, and Illinois predominately specify continuous rigid pavement and may be poor potential markets for alternative material dowels.
- Initial costs and maintenance costs appear to be the most important bases upon which highway designers choose materials, however, life-cycle costs appear to be increasing in importance.
- For the last ten years, PCC paving has accounted for approximately 22% of the total pavement market in the United States.
- The potential market for alternative material dowels in rehabilitation projects appears to be quite small compared to new paving, accounting for only an estimated 925,000 dowels per year in the United States (estimated 5% of new pavement).
- Many metallic and non-metallic coatings of traditional carbon-steel dowels have been attempted and met with mixed results. Epoxy coating appears to be predominate.
- Of the alternatives to traditional steel, glass fiber-reinforced plastic appears to be the most popular, with the use of E-glass encapsulated in vinyl-ester and epoxy resins predominate.
- The three most common failures in transverse joints are joint seal damage, spalling, and faulting.
- Research investigations into the use of alternative materials for highway dowels have determined that FRP may be used when correct diameters and spacings are specified and stainless-steel may be reliable and cost effective, however, many questions involving the optimal design and corrosion resistance of these materials have yet to be answered. [29]

Report: "Field Instrumentation of Dowels, Final Report" (May 1997) [30]

As stated in the report,

The objectives of this study were

- To compare the performance of the four different dowel bar types used in the project. These four types are: 1.5 in. diameter steel and fiberglass dowels and 1.5-inch high steel and fiberglass I-beams.
- To measure the forces placed on dowels by environmental effects, namely temperature-induced curling of the concrete slab.

Both objectives of this research are attempts at improving the problematic area of concrete roadway joints by experimenting with different dowel bar materials and shapes. In addition, this research will show, possibly for the first time, how the environment affects dowel bars.

The scope of this study included

- The comparison of all four bars types of similar dimensions and mechanical properties. The dowel bars were compared not only to each other in response to dynamic loading but also will be monitored for loads induced by environmental effects in the field.
- An analysis of environmental versus dynamic effects for each dowel type. The magnitudes of forces created in dowel bars by various environmental conditions, namely temperature-induced slab curling and moisture-related warping are analyzed in the field.

Conclusions made from this project report:

Based on the results of the Falling Weight Deflectometer (FWD) testing, the following conclusions can be made for dynamic performance of the four dowel types:

- The dowel bars with higher stiffness and/or greater moment of inertia transferred higher loads across the joint.
- The magnitudes of the loads transferred by the steel dowels and steel I-beams were similar. The 1.5 in. diameter steel dowels carried slightly higher forces, except at the on-joint drop location.
- The fiberglass I-beams experienced the lowest moments of the four dowel types.
- The 1.5 in. diameter steel dowels performed the most effectively of the four dowel types.

Based on the results of the environmental testing, the following conclusions can be made of the four dowel types:

- A similar pattern of force magnitudes seen in the FWD testing was observed in the results of the environmental testing.
- The 1.5 in. diameter steel dowels underwent the highest changes in moment of the four dowel types. The 1.5 in. diameter fiberglass dowels experienced changes of moment slightly higher than the steel I-beams.
- The fiberglass I-beams experienced very small moment changes relative to the other dowel types.

Based on the results of both FWD and environmental testing, the following comparisons and conclusions can be made:

- The 1.5 in. diameter steel and fiberglass dowels and the steel I-beams experienced higher moments during environmental testing than during FWD testing, despite the dynamic FWD loading being very much heavier than that the pavement experiences from truck loading.
- The fiberglass I-beams experienced similar magnitudes of moment during both types of testing.
- In general, forces due to environmental causes are more significant than dynamic loads. In addition to transferring dynamic loads across joints, dowel bars serve as mechanisms to reduce curling of slabs due to temperature gradient. [30]

Report: "Load Transfer Design and Benefits for Portland Cement Concrete Pavements" (1997) [4,31]

As stated in reference [4],

Throughout time, several methods have been developed to enhance performance at transverse and longitudinal joints. Some of the more common methods are increasing slab and base course thickness to improve aggregate interlock, protecting the base and subgrade against water intrusion, installing permeable bases, reducing joint spacing, and installing load transfer devices. Industry practice and research have determined that smooth, round, corrosion-resistant dowel bars are typically most effective in maintaining load transfer throughout the life of a pavement. This guide provides a summary of the benefits and design procedures that are applicable when dowel bars are used as a load transfer device. [4]

Report: “Mechanistic Design and Analysis Procedure for Doweled Joints in Concrete Pavements” (1997) [4,32]

As stated in reference [4],

This paper provides a rational, mechanistic method for analysis, design, and evaluation of doweled joints in concrete pavements. The required inputs to the analytical model are the slab thickness, modulus of subgrade reaction, and the radius of the loaded area. All other model inputs can be set at default values or modified at the designer’s discretion. Dowel bar diameters and spacings can then be interactively modified by the designer to yield a given level of load transfer capability at the joint. The same relationships can be used to evaluate the load transfer efficiency of in-service joints by entering FWD-measured joint deflections. The method can be used to back-calculate joint material and structural properties, as well as stress load transfer at the joint. The design and analysis procedures presented in this paper ignore the effects of curling and warping. Obviously, daily and seasonal temperature and moisture cycles have a significant influence on pavement response. Further investigation of the effects of environmentally induced responses is needed. [4]

Report: “Prevention of Joint Faulting Based on Field Performance Modeling” (1997) [4,33]

As stated in reference [4],

This paper describes the development of faulting prediction models for doweled and undoweled joints, based on mechanistic concepts as well as analysis of field data. Site conditions (traffic, climate, and subgrade) and several design features (dowel diameter, subdrainage, joint spacing, base type, and slab welding) were found to enter significantly into the faulting prediction models. [4]

Report: “FRP Dowels for Concrete Pavements” (May 1999) [34]

As stated in this thesis,

The objective of this research was to investigate the behavior of FRP dowels for transverse construction joints of a concrete highway pavement under the effect of typical traffic loading conditions. The behavior of glass fiber reinforced polymer (GFRP) dowels is compared to that of epoxy coated steel dowels. Two different types of GFRP dowels are used in this investigation; Glasform dowels produced by Glasform Inc. in San Jose, California and FiberDowels produced by RJD Industries in Laguna Hills, California.

The scope of this study included

This research encompasses testing of GFRP and steel dowels using a scaled model of a concrete pavement slab section subjected to static and cyclic loads. The scaled model represents a portion of a full thickness, 254 mm (10 in.), concrete pavement slab with a limited length, 2440 mm (8 ft), and width, 610 mm (2 ft). A simulated half axle truckload was applied on one side of the joint until failure.

The research program consisted of testing twelve slab specimens. The first nine were tested under monotonic load whereas the final three slabs were tested under cyclic

loading conditions. Considered in this program are the level of subgrade support and the type of dowel material.

Conclusions made from this project report:

- This investigation of the behavior of GFRP dowels has shown that GFRP dowels can be used in place of the standard steel dowels. Not only do the GFRP dowels transfer sufficient load to an adjacent slab, but do so over the service life of a highway pavement.
- Three materials were tested within this investigation. The top performing material was the Glasform dowel followed by the epoxy-coated steel dowel, and finally the FiberDowel product. All doweled joints performed above the 75 percent joint effectiveness acceptance level while the Glasform consistently performed above 90 percent.
- The diameter of the GFRP dowels was 38 mm (1.5 in.) compared to 32 mm (1.25 in.) for the standard epoxy coated steel dowels. The larger diameter provided two advantages, higher shear stiffness of the dowel and lower bearing stresses on the concrete. These features are the reason for the improved performance of the GFRP dowels despite their low shear strength.
- The use of deicing salts creates a harsh corrosive environment which deteriorates steel dowels. Epoxy coated dowels are relatively protected, however, dents, and cracks in the epoxy layer provide entry points for corrosion. GFRPs are a corrosion resistant material which will require no maintenance during the life span of the pavement. With continued support from the City of Winnipeg and the Department of Highways and Transportation, full utilization of corrosion resistant load transfer mechanisms could soon be standard practice in the pavement construction industry. [34]

Report: "SHRP Joint Study: A Seven Year Look" (1999) [4,35]

As stated in reference [4],

In 1991 and 1992, test sites were constructed to evaluate the performance of joint seal materials and installation methods in new and old concrete. Five joint resealing sites were installed under the Strategic Highway Research Program (SHRP) project H-106 using 12 materials and 4 installation methods. Additionally, 6 new joint sealing sites were installed under the SHRP SPS-4 supplemental testing program using 20 materials and 5 installation methods. Yearly rigorous evaluation of the effectiveness of these seals have been conducted, providing 7 years of performance data regarding adhesion and cohesion failure, spall distress, and compression seal failures.

This paper summarizes the final analysis results from these studies, providing material effectiveness rankings, life cycle cost evaluations, installation method rankings, and other performance results. [4]

Report: “Load-Deflection Behavior of Smooth Dowels” (November 1999) [36]

As stated in this paper,

The focus of this study was to gain basic insight into the load-deformation response of a dowel embedded in concrete.... A test program was conducted to determine the load-deflection characteristics of a doweled joint interface representative of a pavement joint. A laboratory experimental technique was developed to directly measure deflections of the embedded dowel. Three concrete strengths, three dowel diameters, and two joint opening widths were tested.

The conclusions made from this study were

- Concrete strength, dowel diameter, and joint opening width can have substantial impact on the ultimate strength and elastic dowel-concrete interaction of an interface containing a smooth dowel.
- In the elastic range, use of Timoshenko’s analytical expression produced mixed success in back-predicting the measured displaced shape of embedded dowels from tests with different concrete strengths, dowel diameters, and joint widths. Large variations in the modulus of dowel support k were required to produce agreement of deflections at the joint face between theory and experimental data. Furthermore, larger values of k than might be expected were needed. In many cases, when agreement was realized near the face of the joint, displacements at other locations along the embedded length were still discrepant and vise-versa. Additional data is needed to relate a particular value of k to joint geometric, stiffness, and strength properties to accurately predict deflections near the joint face.
- For a given test, a single value of the modulus of dowel support could not be used to back-predict the experimentally observed dowel deformations. The modulus of dowel support had to be adjusted depending on the level of applied load (even in the joint’s global linear range). Timoshenko’s equation, which is based on linear elastic principles, does not account for the complex nonlinear behavior associated with dowel yielding and locally high bearing stresses around the dowel. [36]

Report: “Matching Load Transfer to Traffic Needs” (May 2000) [4,37]

As stated in reference [4],

Current pavement design in Iowa calls for the inclusion of load transfer dowels in transverse joints in both state and local pavements. The dowels have been included to protect the pavement against faulting of the joints and other forms of distress resulting from erosion of the soils from beneath the joints. Faulting has been found to be present mostly at the outer edges of the driving lane. Iowa Highway Research Board Project TR-420 is directed at the evaluation of placing alternative numbers of dowels in the transverse joints of the pavement. A rural and an urban pavement were selected for the test sites on county highways near Creston, Iowa. The sites include subsections containing zero dowels in the transfer joint, three or four dowels in the outer wheel path

only, and a full basket of dowels across the joint. This paper will discuss the results of the deflection testing in both wheel paths in both pavement directions on the rural and urban sections. Fault measurements, joint opening widths, and visual distress surveys have been conducted twice per year on each of the projects. The construction projects are now one year old and the response to load in each case can now be evaluated. [4]

Report: "Long Term Pavement Performance Findings Pay Off For Pennsylvania" (February, 2000) [4,38]

As stated in reference [4],

The Pennsylvania Department of Transportation (PennDOT) decided to change its practice of using skewed joints after reviewing the results of a Long Term Pavement Performance (LTPP) program analysis project. The project analyzed LTPP pavement performance data to identify what worked and what didn't work to control the development of joint faulting. As of calendar year 1999, Pennsylvania policy specified perpendicular joints for any limited-access, four-lane concrete pavement highway projects. By changing its pavement joint design standard, PennDOT can reduce the occurrence of joint faulting and realize the following benefits: a smoother ride for motorists; reduced construction problems and related costs; reduced maintenance requirements; and fewer maintenance-related disruptions to traffic. [4]

Report: "Glass Fiber-Reinforced Polymer Dowels for Concrete Pavements" (March 2001) [39]

As stated,

This paper presents laboratory and field results on the performance of GFRP dowel bars used in transverse joints of concrete pavements. The study included static and cyclic laboratory testing in addition to field-testing using the falling weight deflectometer. Three types of GFRP were tested in addition to epoxy-coated steel. The paper provides information on load transfer in pavements and the feasibility of using GFRP in this application.

Conclusions made from this paper:

GFRP dowels are a viable, corrosion-free alternative to steel dowels. Test results at the laboratory level using two GFRP dowel types, as well as a field application using three types of GFRP, indicate similar performance of GFRP as dowels for concrete pavements in comparison to steel dowels. The study included static and cyclic loading tests using a full-scale model of concrete pavement slab/joint system. The laboratory testing showed that joint effectiveness or load transfer efficiencies are acceptable. The GFRP with relatively higher shear strength resulted in a better performance than GFRP with lower shear strength. Under dynamic (impact) field-testing, the three tested types of GFRP dowels exhibited higher joint deflections (lower joint stiffness) than steel dowels. Once again the performance is consistent with the shear strength of these dowels. Presently there is no design provision for limiting deflections at joints. Although higher deflections are typically associated with loss of support and shorter pavement service life, this may not be the case for GFRP. In fact, the lower flexural stiffness modulus of GFRP compared to the stiffness modulus of steel and the larger dowel diameter are both advantageous in this type of application because of the reduced bearing stresses on the

concrete surrounding the dowel. Bearing stresses are one of the major causes of joint failure. [39]

Report: TR-408. "Investigation of Glass Fiber Composite Dowel Bars for Highway Pavement Slab." (June 2001) [2]

This report consists of four phases. The objectives and scopes for each as stated in the report are as follows:

The objectives for Phases I–IV of this study were

- to determine the material properties of all the GFRP dowel bars,
- to investigate the behavioral parameters of aged GFRP dowel bars under elemental static testing,
- to investigate the behavioral parameters of unaged GFRP dowel bars under elemental static testing,
- to investigate the behavior of aged GFRP dowel bars under elemental fatigue loading (0.5 to 1 million cycles),
- to investigate the behavior of unaged GFRP dowel bars under elemental fatigue loading (0.5 to 1 million cycles) in a full-scale test,
- to investigate the fatigue behavior of GFRP dowel bars under an accelerated partial design life number of cycles (3-5 million),
- to determine the bond characteristics of both aged and unaged GFRP dowel bars,
- to evaluate the condition of dowel bars placed in actual highway joints,
- to investigate the failure modes and adequacy of alternate dowel bar parameters,
- to develop a finite element model of a jointed concrete highway pavement, and
- to compile the results of the study into a final report and possible standards.

The scope of Phase I included the following tasks:

- the investigation of fatigue behavior of unaged GFRP and steel dowel bars in the modified American Association of State Highway & Transportation Officials (AASHTO) test set up,
- the investigation of the direct shear strength of unaged GFRP and steel dowel bars in the Iosipescu test set up,

- the investigation of failure modes of the dowel concrete system using altered cross-sectional parameters of unaged GFRP and steel dowel bars in the Iosipescu test set up,
- the investigation of bond strength of unaged GFRP and steel dowel bars in the elemental pullout format,
- the investigation of mechanical and material properties of GFRP through burnout, flexure and tensile testing and compare values with manufacturer specifications,
- the development of a finite element model of the dowel concrete pavement joint system based on the results obtained from Tasks 2 and 5 above, and
- the aging of specimens for Phase II.

The scope for Phase II of this study included

- the investigation of fatigue behavior of aged GFRP and steel dowel bars in the modified AAHSTO test set up,
- the investigation of the direct shear strength of aged GFRP and steel dowel bars in the Iosipescu test set up,
- the investigation of bond strength of aged GFRP and steel dowel bars in the elemental pull-out format,
- a finite element model to verify the laboratory test arrangement for implementation in Phase III, and
- a theoretical model to investigate dowel bar spacing, diameter, and shape.

The scope for Phase III of this study included

- the investigation of the fatigue behavior of GFRP and steel dowel bars in a full-scale test setup at a high number of cycles. Two test slabs were designed from the elemental testing and analysis conducted in Phases I and II, and
- the investigation of the behavior of dowel bars placed in Highway 30 by subjecting joints to service loading and measuring deflections.

The scope for Phase IV of this study included

- the development of comprehensive design criteria for using GFRP dowel bars as load transfer devices in transverse highway pavement joints; the criteria were products of the entire scope of GFRP research conducted at Iowa State University and relevant material from outside sources,

- the recommendation of a test standard to determine the shear properties of the dowel-concrete system for both GFRP and steel products; the recommendations are proposed for an ASTM or AASHTO standard, and
- a final report that summarizes and coordinates the results of all four phases of the project.

Conclusions made from this project report:

The following conclusions were made with regard to the results of this research and pertain to contraction joints within concrete pavements. (These conclusions may not apply for expansion joints.)

- The jointed plain concrete pavement (JPCP) model created for this study for full-scale slabs was successfully verified by comparing the results from the JPCP model for a pavement of assumed parameters to available theoretical and numerical solutions.
 - The two dowel elements developed in this study accurately model the behavior of a dowel embedded in concrete.
 - Actual field conditions are simulated by the laboratory test setup.
 - All instrumentation, except for the strain gages attached to the dowel bars, was successful in collecting useful data for investigating the effectiveness of a GFRP dowel system in transferring load.
 - The test procedure was effective in monitoring the fatigue performance of the GFRP dowels.
 - The 1.5-inch diameter GFRP dowels spaced at 12 inches on center were inadequate in transferring load for the anticipated design life of the pavement.
 - The 1.5-inch diameter GFRP dowels spaced at 6 inches on center were effective in transferring load over the anticipated design life of the pavement.
 - The current design guideline for steel dowels cannot be applied to GFRP dowels.
- [2]

Report: "Performance of Dowel Bars and Rigid Pavement, Final Report" (June 2001) [40]
As stated in the report,

The general purposes of this study were to evaluate dowel response under a variety of loading and environmental conditions in the field, and to compare the measured responses of different types of dowel bars. Specific objectives included the following:

- Instrument standard steel and fiberglass dowel bars for the monitoring of strain induced by curing, changing environmental conditions and applied dynamic forces.
- Install these dowel bars in an actual PCC pavement at the time of construction.
- Record strain measurements periodically over time to determine forces induced in the dowel bars during curing and during changing environmental conditions.
- Record strain measurements in the dowel bars as dynamic loads are applied with the Falling Weight Deflectometer (FWD).
- Evaluate strain histories recorded for this in-service pavement.

Conclusions made from this project report:

Based upon data obtained from the instrumented dowel bars on U.S. 50 in Ohio during environmental cycling in the field, the following conclusions can be made for steel and fiberglass dowel bars:

- Steel dowel bars induced higher environmental bending moments across transverse PCC joints than fiberglass dowel bars.
- Both types of dowels induced a permanent bending moment in PCC pavement slabs during curing. The magnitude of this moment appears to be a function of bar stiffness.
- Curling and warping during the first few days after concrete placement can result in high bearing stresses being applied to concrete around the dowel bars. This stress may possibly exceed the allowable bearing stress of the concrete at that early age and results in some permanent loss of contact around the bars.
- Data shown in this report were obtained in the late fall and early winter months. High mid-summer temperature gradients in the pavement may result in even larger stresses being induced in the dowel bars and in the surrounding concrete, though concrete strength would also rise more rapidly during that time of the year.

Initial FWD testing took place on December 3, 1997, soon after construction was completed and when the weather was cold and wet. A second set of measurements was obtained on November 15, 1999. Based on the results of these tests, the following conclusions can be made regarding the dynamic response of steel and fiberglass dowel bars:

- On this project, the magnitude of bending moments and vertical shear forces transferred by steel dowels across transverse PCC joints was much higher than for fiberglass bars of the same size.
- The dynamic bending stresses induced in steel and fiberglass dowel bars by a 12,800 lbf FWD load were considerably less than environmental bending stresses induced by a 3°C (5.4°F) temperature gradient in these PCC slabs.

Based upon the combined results of dynamic and environmental testing, the following conclusions can be made:

- During these tests, steel and fiberglass dowels both experienced higher moments from environmental factors than from dynamic loading.
- The effects of environmental cycling and dynamic loading both must be included in the design and evaluation of PCC pavement joints.
- In addition to transferring dynamic loads across PCC pavement joints, dowel bars serve as a mechanism to reduce the curling and warping of slabs due to curing, and temperature and moisture gradients in the slabs.

Because of the high bearing stresses that can be generated in concrete surrounding dowel bars, this parameter should be considered in dowel bar design, especially during the first few days after placement of the concrete. [40]

Report: "Dowel Bar Optimization: Phases I and II" (July 2001) [41]

As stated in the report,

The objectives of Phases I and II were

- to investigate the static behavior of steel elliptical and round epoxy coated dowel bars,
- to investigate the failure modes of steel elliptical and round epoxy coated dowel bars,
- to evaluate the benefits and drawbacks of elliptically shaped dowels bars for load transfer,

- to determine the effect of dowel bar spacing and projected load transfer efficiency, and
- to evaluate if variable spacing in combination with shape factor and bar size can optimize costs and constructability.

The main objective of this research was to determine which dowel bar and spacing should be used for the testing during Phase III, a full-scale accelerated laboratory test.

The scope of this study included

- construction of elemental specimens for static direct shear testing of steel elliptical and round epoxy coated dowel bars,
- testing of elemental specimens under direct shear loading,
- analyzing results from direct shear tests to determine the modulus of dowel support, K_o ,
- analyzing results using K_o to determine the concrete bearing stress at the face of the joint, σ_b ,
- compiling all available information on dowel bar spacing, and
- analyzing the effect of dowel bar spacing on concrete pavements.

Conclusions made from this project report:

- The results of this research indicated that the elliptical dowel bars behaved as predicted. When comparing the 1-1/2" ϕ round epoxy coated steel dowel bars to the large elliptical steel dowel bars, the large elliptical steel dowel bars produce bearing stresses on the concrete that are greatly reduced while the increase in relative deflection is minimal.
- The large elliptical steel dowel bars have an increase in cross-sectional area of nearly 18% but provide a reduction in bearing stress of over 26%. In contrast, the 1-1/2" ϕ round epoxy coated steel dowel bars have a 44% increase in cross-sectional area over the smaller 1-1/4" ϕ round epoxy coated steel dowel bars yet only provide a 25% reduction in bearing stress.
- The round dowel bars did retain a slight advantage in the stiffness over elliptical dowel bars of a similar cross-sectional area due to their shape. However, this difference in stiffness is insignificant based on the small variance in the deflection of the slabs. The difference in magnitude of the deflections is so small that the dowel bars could be considered as having roughly the same deflection.

- This research has shown that the 1.5” ϕ round epoxy coated steel dowel bars have roughly same bearing stress as the medium elliptical dowel steel bars. This occurrence could be beneficial if the load transfer efficiency was determined.
- This research has shown that the 1.5” ϕ round epoxy coated steel dowel bars have roughly same bearing stress as the medium elliptical dowel steel bars. This occurrence could be beneficial if the load transfer efficiency was determined.
- Dowel bar spacing is a method to distribute load to the dowel bars. The smaller the spacing of the dowel bars the smaller the load on the dowel bars. A decrease in pavement thickness will lower the number of bars available for load transfer and a smaller spacing may be required.
- Poor subgrade material will also decrease the number of dowel bars available for load transfer and therefore a smaller spacing may also be needed. [41]

Report: “Fatigue behavior of glass fiber reinforced polymer dowels” (May 2001) [42]

As stated in this research report,

The objectives were

- to develop a computer model that accurately predicts a rigid pavement’s response to vehicle loading,
- to verify the full-scale fatigue laboratory test setup used in previous research at Iowa State University [1]
- to investigate the static and fatigue behavior of GFRP dowels, and
- to recommend a preliminary design procedure for the incorporation of GFRP dowels in transverse joints of concrete highway pavements.

The scope of this research program was as follows:

- Construction of a finite element model for the analysis of jointed plain concrete pavement (JPCP)
- Construction of a finite element model for the verification of the laboratory test setup
- Development of an element that can be used in both computer models that accurately models the behavior of a dowel bar embedded in concrete
- Determination of an equivalent spacing for various diameters of GFRP dowel bars

- Construction of two full-scale laboratory pavement specimens: one containing 1.5-inch diameter GFRP dowels spaced at 12 inches and the other containing the same diameter GFRP dowels spaced at an equivalent spacing, as determined from the theoretical portion of this research program
- Subjection the two full-scale specimens to 5,000,000 cycles of cyclic loading
- Analysis of the results from the fatigue test to determine the effectiveness of the doweled joints
- Development of a design methodology based on the results from this research, previous research, and the research of others for the implementation of GFRP dowels

The following conclusions were made from the results in this research project.

- The jointed plain concrete pavement model created for this study was successfully verified by comparing the results from the JPCP model for a pavement of assumed parameters to available theoretical and numerical solutions.
- The two dowel elements developed in this study accurately model the behavior of a dowel embedded in concrete.
- Actual field conditions are simulated by the laboratory setup.
- The steel supporting beams simulate a soil having a modulus of subgrade reaction equal to 145 pci.
- All instrumentation, except for the strain gages attached to the dowel bars, was successful in collecting useful data for investigating the effectiveness of a GFRP dowel system in transferring load.
- The test procedure followed during testing was effective in monitoring the fatigue performance of the GFRP dowels.
- The 1.5-inch diameter GFRP dowels spaced at 12 inches on center were inadequate in transferring load.
- The 1.5-inch diameter GFRP dowels spaced at 6 inches on center were effective in transferring load over the design life of the pavement.
- The current design guideline for steel dowels cannot be applied to GFRP dowels. [42]

Report: "Using the Minnesota Accelerated Loading Facility to Test Retrofit Dowel Load Transfer Systems" (2001) [43]

As stated in the report,

The objective of this project was the development, construction, and demonstration of the Minnesota Accelerated Loading Facility (Minne-ALF) for rapidly accumulating simulated heavy traffic loads on pavement test slabs. The test stand demonstration included tests of a typical Minnesota Portland cement concrete (PCC) pavement design constructed on a composite foundation (natural base and soil over artificial foundation matting). Demonstration test variables included the use of various types and sizes of dowel bars (retrofit across transverse cracks and joints in the test slabs) and the use of different types of backfill material for the dowel slots that the Minnesota Department of Transportation (Mn/DOT) has either applied in the field or anticipates using in future construction or rehabilitation projects. Therefore, the intent of this testing was to determine the relative long-term performance potential of the given load transfer systems and to use this information to assist in deciding whether to use or continue using these systems in future field applications.

Conclusions as stated in this report:

- The Minne-ALF appears to be a useful tool for evaluating the relative performance potential of rigid pavement designs and design features.
- The use of Speed Crete 2028 in lieu of MnDOT 3U18 concrete backfill improved load transfer system performance. This result is probably because of the higher early age strength and better consistency during placement of the proprietary material.
- Reducing the dowel length from 38 cm to 33 cm appears unlikely to significantly reduce performance potential for properly sized and installed retrofit dowels.
- The use of stainless steel-clad dowels did not appear to significantly reduce the performance potential of retrofit dowel installation when compared with that of epoxy-coated steel dowels. However, tests of the use of fiber-reinforced plastic and grout filled stainless steel tubes suggest that long-term performance potential may be reduced because of the higher flexibility of these systems.
- At this time, it is very difficult to relate the number of load applications in the Minne-ALF to a number of load applications in the field. On one hand, every load applied by the Minne-ALF can be considered a critical load in terms of both placement and magnitude; this would suggest that even higher numbers of loads might be expected in actual field applications where loads are not highly channelized and critically placed. On the other hand, many factors are present in the field (e.g. pavement curling and warping, opening and closing of joints, changes in concrete strength and condition with time, seasonal variations in foundation stiffness) that have not yet been (or cannot be) adequately considered on laboratory-based accelerated testing programs. These factors often

significantly reduce performance in the field. For these reasons, it is best to consider the Minne-ALF (and most other accelerated load testing facilities) to be capable of providing a good indication of only the relative performance potential of different designs and design features. [42]

Current Running Alternative Dowel Bar Projects

Project: “Field Evaluation of Alternative Load Transfer Device Locations in Low Traffic Volume Pavements” (Started in July 1998) [44]

Investigator: James Cable, Iowa State University, Ames, IA

As stated in this project statement,

Objectives:

The project seeks to evaluate the effect of reducing the number of dowels in a low-volume pavement transverse joint.

Description:

Two projects in Union County, Iowa have been used to conduct the study. One rural pavement on granular base has been outfitted with 20 joints each including no dowels, three dowels, and four dowels in the outer wheel path. A similar study on a county/city street employs ten joints of each pattern and a pavement overlay of an existing asphalt roadway. The joints will be monitored for opening width, faulting, visual distress, and deflection in both wheel paths for five years to evaluate performance. [44]

Project: “Identification of Critical Stress Concentration Around Dowel Bars” (Started in August 1998) [44]

Investigator: Samir Shoukry, West Virginia University, Morgantown WV

As stated in this project statement,

Objectives:

Use of nonlinear 3D-FEM to identify the distribution of critical stresses surrounding doweled transverse joints subjected to thermal and moving traffic loads. Alternative dowel and/or transverse joint design will be developed to eliminate the points of high stress concentration, which lead to joint failure thus improve load transfer efficiency and reduce maintenance cost.

Work Plan:

In recent years, West Virginia University (WVU) researchers have taken steps toward developing a mechanistic approach for studying different types of pavements. Explicit nonlinear three dimensional finite element modeling (3D-FEM) was used to simulate the dynamic response of different types of pavement structures to impact loads. The 3D-FEM results showed excellent correlation with the experimental results. Models were developed to investigate the response of rigid, flexible, and composite pavement response to a Falling Weight Deflectometer (FWD) load. The response of a thermally warped slab to FWD load was also modeled. Preliminary results obtained for the Y-stress

distribution around the dowel bars indicate that techniques could be developed to prevent the concentration of stresses at the interfaces between the dowels and the supporting concrete. The improvement can be achieved through improving the load transfer between the dowels and the surrounding concrete. Thus, without significant increase in the construction cost, pavement joints could be designed to last longer, maintenance cost could be reduced, and the ride quality maintained for a longer time period. [44]

Project: "Influence of Special Design Variables Upon Rigid Pavement Performance Regarding Contraction Joints" (Started in 1990) [44]

Investigators: Minnesota Department of Transportation, St. Paul, MN

As stated in this project statement,

Objectives:

The objective of this research is to identify optimum contraction joint design parameters under in-situ Minnesota roadway conditions. Minnesota Department of Transportation design standards will be modified if they do not reflect the optimum parameters confirmed by this research project. A secondary objective of this research is to develop a method for nondestructive testing of deteriorated contraction joints that will sufficiently characterize their condition so appropriate repair actions can be recommended.

Scope:

Low Volume road cells with 1-inch dowels and no dowels, as well as ten-year mainline cells with 1.25-inch dowels and 1.5-inch dowels will be the focus of this project. Two outside lane contraction joints in each of the 4 cells will be instrumented. Radar will be used to verify the correct placement of dowels during construction. Ride levels and joint efficiency ratings using the falling weight deflectometer will be measured throughout the life of these sections. At the end of the life of these cells, a forensic evaluation will be performed on the instrumented joints to determine their condition.

Contraction joints in the widened pavement area (5-year mainline) will be monitored visually during their life and at the time of the forensic evaluation for additional information.

Background:

The two basic designs used to accomplish vertical load transfer rely on either dowel bars or aggregate interlock. Under ideal conditions, contraction joints are designed to transfer all of the vertical loadings (traffic) and none of the longitudinal (temperature) loadings between rigid pavement slabs.

Unfortunately Minnesota roadway conditions are far from ideal. As a result, the performance of contraction joints diminishes with time. Construction conditions, maintenance operations, weather, and real-world traffic all contribute to the deterioration and possible failure of these joints.

The most pressing performance issue is how to establish and maintain good vertical load transfer so pumping and faulting at contraction joints are minimized. [44]

Project: “Seal Joints, Alternative Dowels” (Started in 1999) [44]

Investigator: Tom Winkelman, Illinois Department of Transportation, Springfield, IL

As stated in the project description,

This research involves the field evaluation of four different experimental features in a PCC pavement joint. The concrete pavement will include polypropylene fibers for reinforcement, no-seal transverse pavement joints, uniform transverse tining, randomly spaced skewed tining, and some alternative materials for dowel bars. Three dowel types are used: Stainless steel, Stainless steel cement grout filled and fiber composite with cement grout filled. [44]

Project: “HITEC Test and Evaluation: Alternative Material Dowel Bars for Rigid Pavements – National Pooled Fund” (Started in 1999) [44]

Investigator: David Reynaud, HITEC, Washington, DC

As stated in the projection description,

Objectives:

The objectives of this evaluation are: a) to assess the constructability, placement verification, environmental qualities and performance capabilities of fiber reinforced polymer dowels and stainless steel dowels to perform the load transfer and joint movement requirements in concrete pavement joints for the full service life of the pavement without detrimental corrosion or deterioration, and b) to consider the comparative performance and service-life costs of these alternative materials and epoxy-coated mild steel for use on dowel bars.

Description:

The problem of deterioration of concrete pavement joints due to dowel bar corrosion has resulted in the search for alternate solutions. Fiber-reinforced polymer (FRP) and stainless steel represent corrosion resistant alternatives to conventional galvanized steel in this application. This is a non-proprietary evaluation program sponsored by the Composites Institute and the Specialty Steel Industry of North America.

Work Plan:

Project Commitments for a pooled-fund totaling \$105,000 from State SP&R funds. Proposals are being accepted from potential consultants to conduct the evaluation in accordance with the HITEC plan. The evaluation will include laboratory testing, field-testing, and demonstration projects. The participating trade associations have provided both FRP composite and stainless steel dowel bars to the Wisconsin DOT for two demonstration projects. The Ohio DOT has removed several joints from experimental projects using FRP dowels installed in the 1980's to check for durability. [44]

Project: “Dowel Bar Retrofit of Rigid Pavements” (Started in 2000) [44]

Investigators: Pavement Research Center, University of California at Berkeley

As stated in this project statement,

The objectives of this research are to

- Determine the effects of dowel size.
- Evaluate the performance of different dowel types, potentially including traditional epoxy coated steel, stainless steel and non-ferrous composite materials with respect to performance in the pavement, corrosion durability of the dowels, and chemical durability of the grout materials.
- Evaluate the load transfer restoration provided by the different techniques and determine whether dowel bar retrofit will provide faulting performance for the 10 to 15 years needed for it to be economically viable.

Description:

Since the early 1950s, Caltrans rigid pavement practices have relied on non-erodable bases and aggregate interlock at the transverse joints to control transverse joint faulting. At that time Caltrans stopped using dowels because of problems encountered with dowel alignment during construction, the relatively small benefit obtained from the small dowels used at the time and the level of traffic at the time.

Currently, Caltrans faulting typically occurs on rigid pavements within several years after construction or reconstruction. Faulting results in a rough ride and can increase noise. Caltrans is moving towards use of dowels in all new construction and reconstruction. Improved techniques for retrofitting existing concrete pavements have been developed over the past seven years by the Washington State DOT, among others. Dowel bar retrofitting consists of sawing grooves, insertion of dowels across the transverse joints and grouting, followed by grinding to remove the faulting and smooth the grout surface.

There results of dowel bar retrofit of rigid pavements will provide Caltrans and other research partners with the information needed to design and construct dowel bar retrofit projects to obtain maximum performance, and to determine where dowel bar retrofit is the most cost-effective strategy for rigid pavement rehabilitation. [44]

Project: “Demonstration and Field Evaluation of Alternative Portland Cement Concrete Pavement Reinforcement Materials” (Started in June 2003) [44]

Investigators: J.K. Cable, S.M. Schlorholtz, Iowa State University, Ames, IA.

As stated in this project statement,

Objective:

The objective of this work is the evaluation of two composite products and one stainless steel product in the reduction of deflections and corrosion in transverse and longitudinal pavement joints over a five-year period.

Description:

This project is being done in conjunction with a laboratory project to evaluate the potential fiber composite and stainless steel as a form of joint reinforcement for concrete pavements. The bars have been installed in a pavement near Des Moines, Iowa and will be evaluated twice each for year for five years. [44]

Project: "Field Evaluation of Elliptical Steel Dowel Performance" (Started in February 2002)
[44]

Investigator: James Cable ND Max Porter, Iowa State University, Ames, IA

As stated in this project statement,

Objectives of study:

Research will strive to answer the following questions:

- What is the relative performance over time of medium-sized and large-sized elliptical (as used in Phases I and II of the laboratory research) steel dowels as compared to that of the conventional steel dowels, in terms of deflection, visual distress, joint faulting, and joint openings?
- What is the impact of dowel spacing on the relative performance of the elliptical and round dowels in field conditions?
- What is the impact on performance of the various dowel shapes when placed in cut or fill sections of the roadway?
- What constructability problems, if any, are associated with the installation of dowel shapes other than round?"

STATE-OF-THE-ART (SOA)/THEORETICAL INVESTIGATION

Dowel Bar Load Distribution

Joint Effectiveness

The effectiveness of a joint is determined by its ability to transfer part of an applied load across the joint to the adjacent slab. There are several methods available for determining the efficiency of a joint. One measure of joint effectiveness is given by Equation 4.1 [45].

$$\text{TLE} = \frac{P_t}{P_w} \times 100\% \quad (4.1)$$

where,

- TLE = transferred load efficiency (%)
- P_t = load transferred across the joint (lbs)
- P_w = applied wheel load (lbs)

If a joint were fully effective in transferring load, half of the applied wheel load would be transferred to the subgrade while the other half would be transferred through the dowels to the adjacent slab. Therefore, the maximum permissible value for transferred load efficiency is 50 percent. Brown and Bartholomew [46] consider a TLE of 35 to 40 percent adequate for heavy truck traffic.

AASHTO and the American Concrete Pavement Association (ACPA) use deflection measurements to determine the efficiency of a joint. Equation 4.2 is given by ACPA as a means of rating joint effectiveness.

$$E = \frac{2 d_U}{d_L + d_U} \times 100\% \quad (4.2)$$

where,

- E = joint effectiveness (%)
- d_U = deflection of the unloaded side of a joint (in.)
- d_L = deflection of the loaded side of a joint (in.)

A joint effectiveness of 75 percent or more is considered adequate for medium to heavy truck loadings [47]. AASHTO gives Equation 4.3 for determining joint effectiveness associated with a 9000 lb wheel load.

$$\text{LTE} = \frac{d_U}{d_L} \times 100\% \quad (4.3)$$

where,

LTE = deflection load transfer efficiency (%)

When the value of LTE is between 70 and 100 percent, the joint provides sufficient load transfer. Deflection measurements for use in Equations 4.2 and 4.3 should be taken at the location of the outside wheel path [48].

Thickness Design

Pavement design involves selecting the appropriate thickness of pavement to limit the flexural stresses in the pavement slab so fatigue cracking will not affect the serviceability of the pavement over its intended design life. The major criterion in the selection of a pavement thickness is the flexural stress in the bottom of the pavement slab. Depending on the load transfer characteristics of the dowel bars, the critical flexural stress for thickness design occurs at one of two locations. If dowel bars provide adequate load transfer, an edge load placed at midslab produces the critical stress and cracking will occur at the bottom edge of the slab, as shown in Figure 4.1. If dowel bars are inadequate in transferring load, joint loading causes the critical stress and longitudinal cracking will initiate in the wheel paths at the transverse joints, as shown in Figure 4.1. Another possibility exists if the joint locks or freezes then a crack can occur across the slab in the vicinity immediately behind the row of dowels, as shown in Figure 4.1.

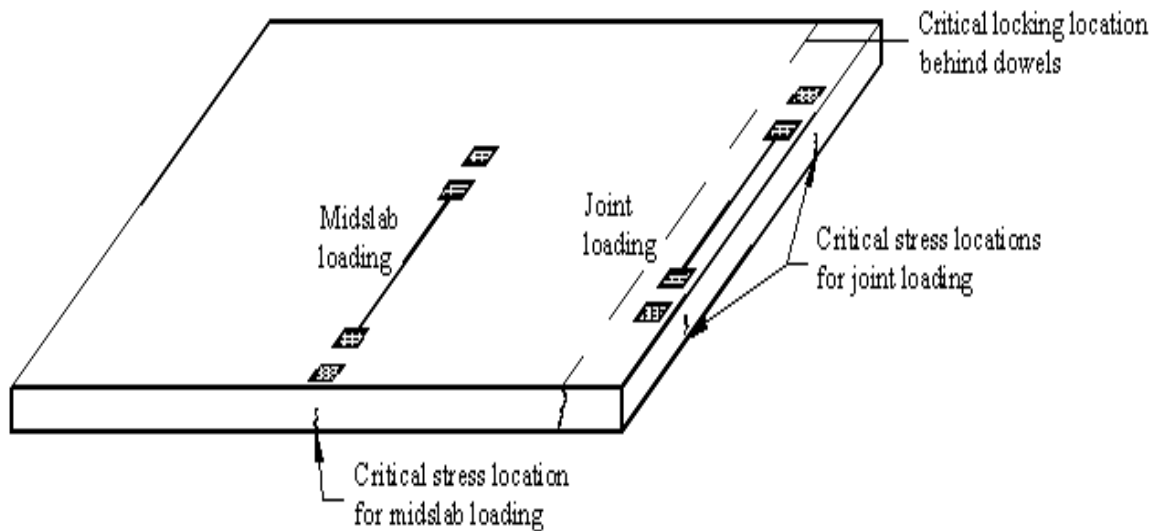

Figure 4.1 Load positions for critical stress

In the thickness design of pavements, the ACPA or AASHTO method is commonly used. In the current ACPA method, the thickness of the pavement is based on the edge stress at midslab. Axle loads are divided into groups, and the flexural stress induced in the bottom of the slab is determined for each group. Based on the ratio between the flexural stress and the modulus of rupture, an allowable number of load repetitions are determined for each group. A damage ratio, defined as the ratio between the predicted and allowable number of load repetitions, is then calculated for each group. Failure is assumed to occur when the sum of the damage ratios for all groups exceeds a value of 1 [49]. Therefore, if the damage ratio for the anticipated design life is greater than one, a thicker pavement is required.

The required thickness of pavement determined by the AASHTO method is based on an empirical equation derived from data obtained from the AASHO Road Test and further modified to incorporate additional knowledge gained from theory and experience. In the AASHTO method, each axle load is converted to an 18 kip equivalent single axle load (ESAL) through the use of equivalency factors. For the anticipated number of ESALs and a specified terminal serviceability index, the empirical equation obtained from the AASHO Road Test is solved to give the required thickness of pavement. The serviceability index is a measure of the performance of the pavement and is based on pavement roughness [48].

Dowel Bar Theory

Introduction

A transverse joint represents a plane of weakness in a concrete pavement. Without load transfer across the joint, stresses and deflections due to joint loading are substantially higher than those due to interior loading. A dowel bar's function is to transmit part of an applied wheel load from the loaded slab across the joint to the adjacent unloaded slab. Therefore, load transfer, through the use of dowel bars, significantly reduces stresses and deflections resulting from joint loading, thus, minimizing faulting and pumping. Faulting is the difference in elevation across the joint of the two slabs, while pumping is defined as the expulsion of subgrade material through joints and along the edges of the pavement. A slab constructed between two army camps near Newport News, Virginia between 1917 and 1918 is thought to be the first concrete pavement to use steel dowels as load transfer devices [50].

Analytical Model

The theoretical model used to predict the behavior of a dowel bar embedded in concrete is based upon the work presented by Timoshenko and Lessels [51] for the analysis of beams on an elastic foundation. According to Timoshenko and Lessels, the differential equation for the deflection of a beam on an elastic foundation is written as follows:

$$EI \frac{d^4 y}{dx^4} = -ky \quad (4.4)$$

where k is a constant usually called the modulus of foundation and y is the deflection. The modulus of foundation denotes the reaction per unit length when the deflection is equal to unity. The solution to this differential equation is given by:

$$y = e^{\beta x}(A \cos \beta x + B \sin \beta x) + e^{-\beta x}(C \cos \beta x + D \sin \beta x) \quad (4.5)$$

where,

$$\beta = \sqrt[4]{\frac{k}{4EI}} = \text{relative stiffness of the beam on the elastic foundation (in}^{-1}\text{)}$$

k = modulus of foundation (psi)

E = modulus of elasticity of the beam (psi)

I = moment of inertia of the beam (in⁴)

The constants A , B , C , and D are determined from the boundary conditions for a particular problem. For a semi-infinite beam on an elastic foundation subject to a point load and moment

applied at its end, as shown in Figure 4.2, constants A and B are equal to zero and Equation 4.5 becomes

$$y = \frac{e^{-\beta x}}{2\beta^3 EI} [P \cos \beta x - \beta M_0 (\cos \beta x - \sin \beta x)] \quad (4.6)$$

Loads P and M_0 are shown in their positive sense in Figure 4.2. The positive direction for deflection is downward. Differentiating Equation 4.6 with respect to x gives the slope, dy/dx , of the beam anywhere along its axis.

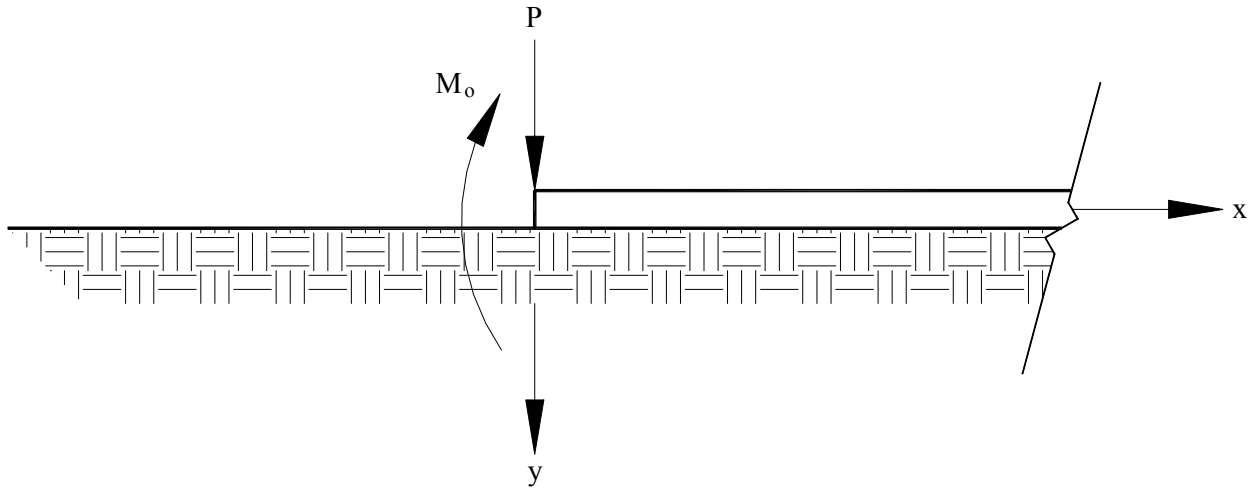

Figure 4.2 Semi-infinite beam on an elastic foundation

$$\frac{dy}{dx} = \frac{e^{-\beta x}}{2\beta^2 EI} [(2\beta M_0 - P) \cos \beta x - P \sin \beta x] \quad (4.7)$$

Applying the solution for a semi-infinite beam on an elastic foundation to dowel bars, Friberg [52] developed equations for determining the slope and deflection of a dowel at the face of a joint as shown in Figure 4.3. Assuming that an inflection point exists in the dowel at the center of the joint, the forces acting on the portion of the dowel within the width of the joint, z , are as shown in Figure 4.4. Substituting $-Pz/2$ for M_0 and setting x equal to zero in Equations 4.6 and 4.7, Friberg arrived at Equations 4.8 and 4.9 for the slope, dy_0/dx , and the deflection, y_0 , of the dowel at the face of the joint.

$$\frac{dy_0}{dx} = \frac{-P}{2\beta^2 EI} (1 + \beta z) \quad (4.8)$$

$$y_o = \frac{P}{4\beta^3 EI} (2 + \beta z) \quad (4.9)$$

where,

$$\beta = \sqrt[4]{\frac{K_o b}{4EI}} = \text{relative stiffness of the dowel bar encased in concrete (in}^{-1}\text{)}$$

K_o = modulus of dowel support (pci)

b = dowel bar width (in.)

E = modulus of elasticity of the dowel bar (psi)

I = moment of inertia of the dowel bar (in⁴)

P = load transferred through the dowel (lbs)

z = joint width (in.)

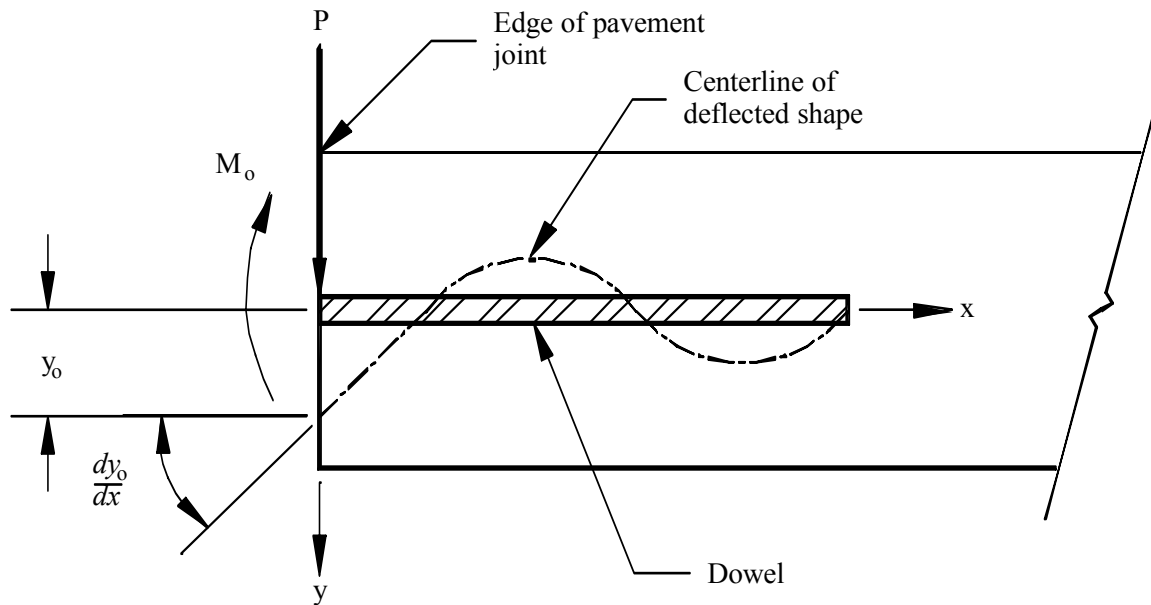

Figure 4.3 Slope and deflection of dowel at joint face

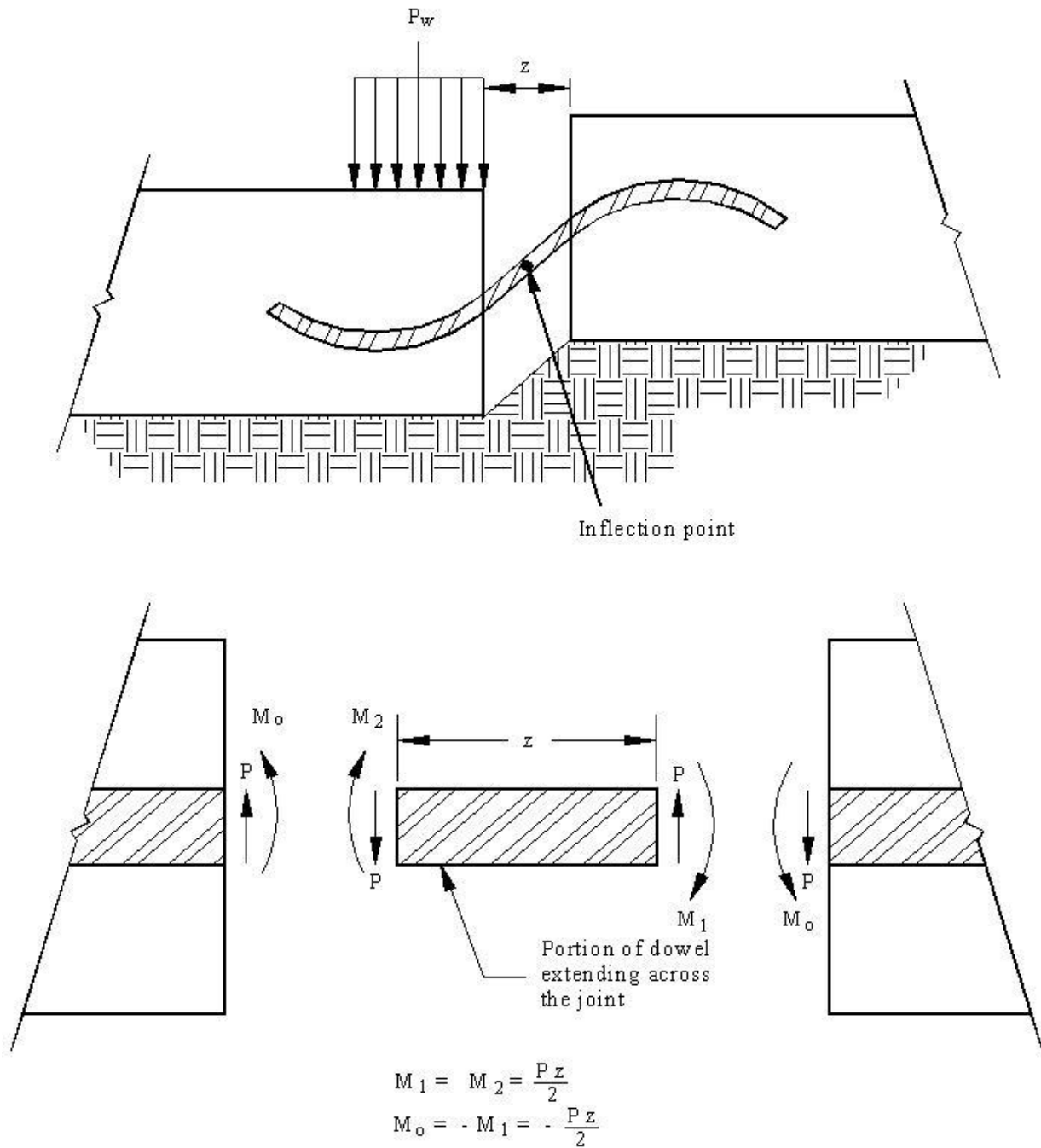

Figure 4.4 Forces acting on dowel

In Friberg's analysis, he replaced the modulus of foundation, k , with the expression $K_o b$. The modulus of dowel support, K_o , denotes the reaction per unit area when the deflection is equal to unity. Further discussion on the modulus of dowel support can be found in Section 4.2.3.

Friberg's equations were derived assuming a dowel bar of semi-infinite length. Dowel bars used in practice are of finite length; therefore, this equation would not apply. However, Albertson and others [1,53] has shown that this equation can be applied to dowel bars with a βL value greater than or equal to 2 with little or no error. The length of the dowel bar embedded in one side of the slab is denoted as L .

Bradbury [54] also developed equations for predicting the response of a dowel bar encased in concrete. However, many engineers view Friberg's work as the authoritative analysis on the behavior of dowel bars to date. Therefore, Friberg's equations were used in accomplishing the theoretical work associated with this research project.

Modulus of Dowel Support

The modulus of dowel support is an important parameter in Friberg's design equations presented in Section 4.2.2. Before a design engineer can use these equations, a value for the modulus of dowel support for the given dowel-concrete system is needed. Since no sound theoretical procedure exists for the determination of this value, the modulus of dowel support must be determined experimentally.

Results from experimental testing indicate a wide range of values for the modulus of dowel support. Researchers at ISU [1,2,11,12,41,55] have determined values for the modulus of dowel support ranging anywhere from 132,790 pci to 2,139,000 pci. Experimental tests conducted by Friberg [56] yielded modulus of dowel support values ranging from 200,000 pci to 5,000,000 pci.

There is also disagreement amongst researchers on what value should be used for the modulus of dowel support in the design of doweled joints. For steel dowel bars Friberg [52] believed that the modulus of dowel support would seldom be less than 25 percent of the modulus of elasticity of the concrete; therefore, he recommended a value of 1,000,000 pci for the modulus of dowel support. Grinter [57] selected values of 300,000 and 1,500,000 pci for use in his work. Yoder and Witzak [58] state that values for the modulus of dowel support range between 300,000 and 1,500,000 pci and recommend a value of 1,500,000 pci for use in design.

Although values of the modulus of dowel support are highly variable and researchers tend to disagree on the correct value to be used in design, researchers do agree that the modulus of dowel support increases with increased concrete strength, decreases with increased concrete depth below the dowel, and decreases with increased dowel bar diameter [56,59].

Load Transfer Across a Joint

If 100 percent efficiency is achieved in load transfer by the dowel bars, 50 percent of the wheel load would be transferred to the subgrade while the other 50 percent would be transferred through the dowels to the adjacent slab. However, repetitive loading of the joint results in the creation of a void directly above or beneath the dowel at the face of the joint. According to Yoder and Witczak [58], a 5 to 10 percent reduction in load transfer occurs upon formation of this void; therefore, a design load transfer of 45 percent of the applied wheel load is recommended.

$$P_t = 0.45P_w \quad (4.10)$$

where,

P_t = load transferred across the joint (lbs)

P_w = applied wheel load (lbs)

Not all dowels are active in transferring the applied wheel load across the joint. Friberg [52] was the first to examine the distribution of transferred load to the dowels within a transverse joint. He assumed that dowel bars close to the load were more effective in transferring load than those farther away. For transverse joints containing 0.75 or 0.875-inch diameter dowel bars spaced from 12 to 20 inches apart, Friberg postulated that only the dowels contained within a distance of $1.8l_r$ from the load are active in transferring the load where l_r is the radius of relative stiffness, defined by Westergaard [60] as follows:

$$l_r = \sqrt[4]{\frac{E_c h^3}{12(1-\mu^2)K}} \quad (4.11)$$

where,

E_c = modulus of elasticity of the pavement concrete (psi)

h = pavement thickness (in.)

μ = poisson's ratio for the pavement concrete

K = modulus of subgrade reaction (pci)

Friberg also proposed a linear distribution of the load transferred across the joint as shown in Figure 4.5. For transverse joints containing dowel bars having a larger diameter or closer spacing, the stiffness of the joint increases and a distance of $1.8l_r$ no longer applies.

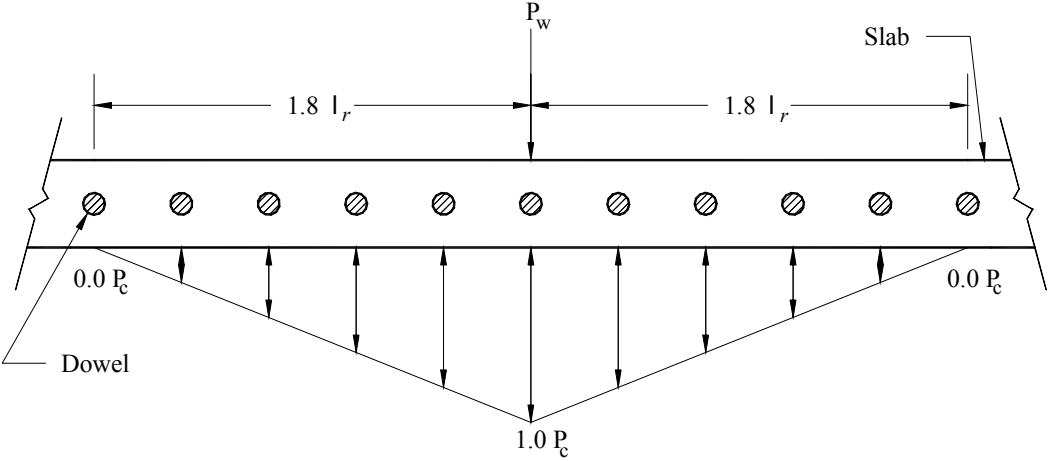

(a)

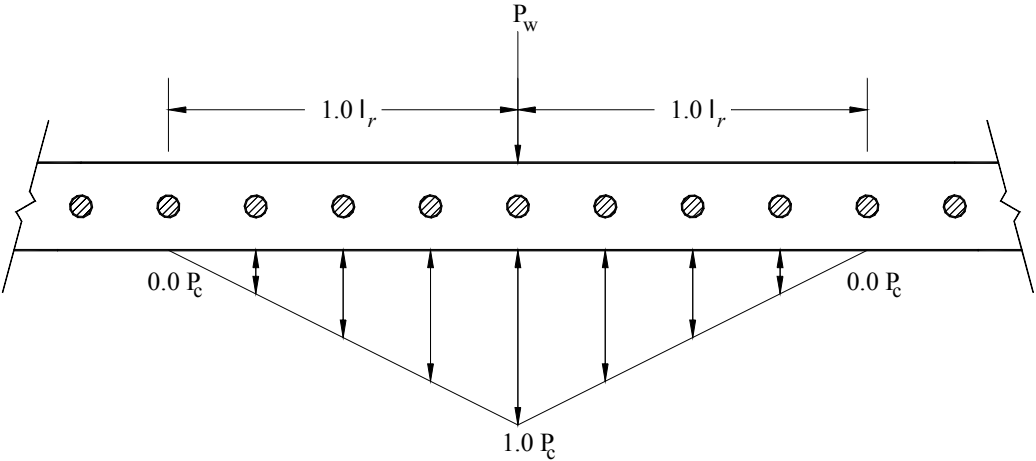

(b)

Figure 4.5 Load transfer distribution proposed by (a) Friberg and (b) Tabatabaie et al.

Finite element modeling of doweled joints by Tabatabaie et al. [61] showed that an effective length of $1.0l_r$ from the applied wheel load is more appropriate for dowels used in practice

today. A linear approximation was also shown to exist with the maximum dowel shear occurring directly beneath the load and decreasing to a value of zero at a distance $1.0l_r$ from the load.

If the force transferred by a dowel located directly beneath the wheel load is designated as P_c , then the shear force in any other active dowel can be determined by multiplying the height of the triangle below that particular dowel by P_c . A value of 1.0 is assumed for the height of the triangle directly below the load as shown in Figure 4.5. The shear force in the dowel directly under the load is obtained by dividing the transferred load, P_t , by the number of effective dowels, as shown by Equation 4.12.

$$P_c = \frac{P_t}{\text{number of effective dowels}} \quad (4.12)$$

The sum of the heights of the triangle under each dowel gives the number of effective dowels.

Relative Deflection Between Adjacent Pavement Slabs

The relative deflection between adjacent pavement slabs, shown in Figure 4.6, consists of the following quantities:

twice the deflection of the dowel at each joint face, $2y_o$;

the deflection due to the slope of the dowel, $z\left(\frac{dy_o}{dx}\right)$;

shear deflection, δ ; and

flexural deflection, $\frac{Pz^3}{12EI}$.

Considering all of these quantities, the relative deflection between adjacent pavement slabs, Δ , is given by the following equation:

$$\Delta = 2y_o + z\left(\frac{dy_o}{dx}\right) + \delta + \frac{Pz^3}{12EI} \quad (4.13)$$

where,

$$\delta = \frac{\lambda Pz}{AG}$$

λ = form factor, equal to 10/9 for solid circular section

A = cross-sectional area of the dowel bar (in^2)

G = shear modulus (psi)

For small joint widths, like the 1/8-inch joint formed in the test specimens of this study, the deflection due to the slope of the dowel is approximately zero since the width of the joint and the slope of the dowel are small. Also, the deflection due to flexural stresses in the dowel within the width of the joint is extremely small since load is transferred across the joint predominantly by shear. Therefore, for small joint widths, the deflection due to the slope of the dowel and flexural stresses can be ignored and the relative deflection between adjacent pavement slabs, Δ , can be expressed as follows:

$$\Delta = 2y_0 + \delta \quad (4.14)$$

For larger joint widths, the deflection due to the slope of the dowel and flexural stresses is significant and should be considered in computing the relative deflection between adjacent pavement slabs.

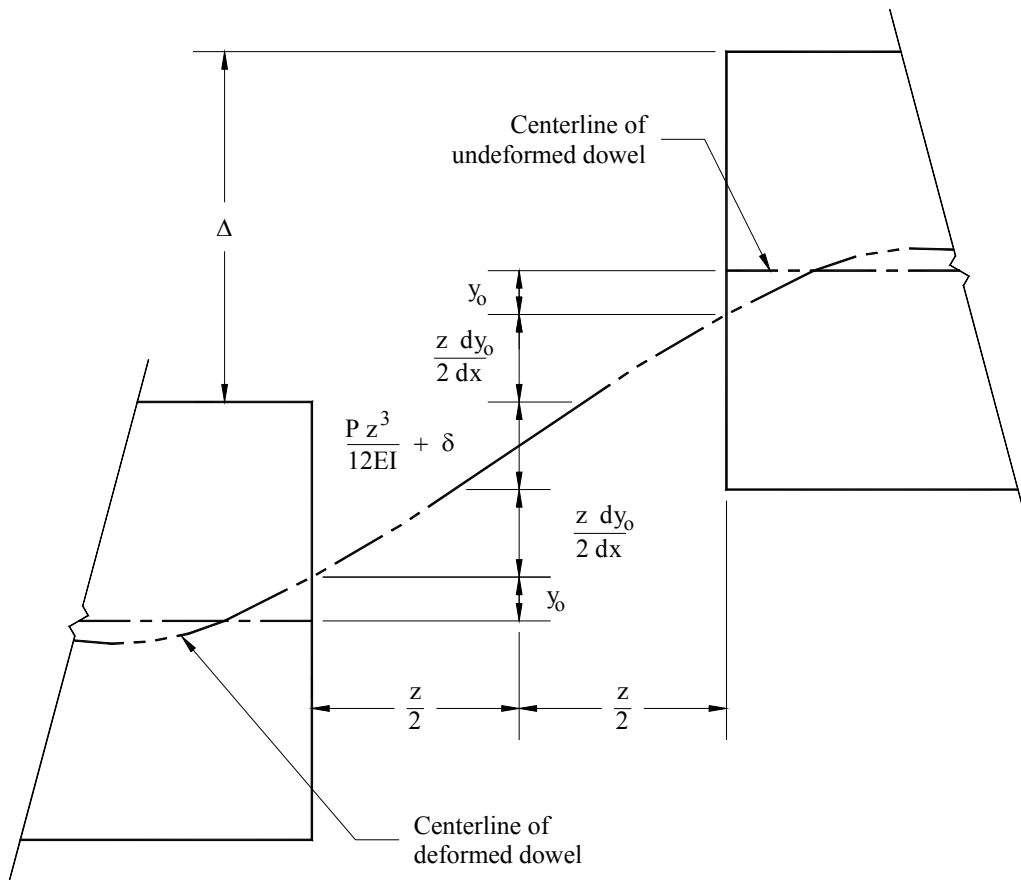

Figure 4.6 Relative deflection between adjacent pavement slabs

Bearing Stress

The load acting on a dowel is transferred to the supporting concrete through bearing. The magnitude of the resulting bearing stresses is critical to the performance of the joint and is the greatest at the face of the joint. Under repetitive loading, high bearing stresses lead to the deterioration of concrete around the dowel, which results in the formation of a void between the dowel and the surrounding concrete. This void is often referred to as dowel looseness. When a load is applied to a slab containing loose dowels, the slab will deflect an amount equal to the dowel looseness before the dowels become active. This looseness results in the loss of load transfer and subsequent faulting of the pavement.

Assuming the dowel behaves as a beam on an elastic foundation, the bearing stress at the face of the joint, σ_o , is directly proportional to the deformation of the concrete at this location and is given by [52]:

$$\sigma_o = K_o y_o = \frac{K_o P}{4\beta^3 EI} (2 + \beta z) \quad (4.15)$$

To ensure adequate joint performance, the bearing stress should not exceed an allowable value. Equation 4.16 gives recommended values for the allowable bearing stress.

$$\sigma_a = \left(\frac{4 - b}{3} \right) f'_c \quad (4.16)$$

where,

σ_a = allowable bearing stress (psi)

b = dowel bar diameter (in.)

f'_c = compressive strength of concrete (psi)

Equation 4.16 was developed by the American Concrete Institute's (ACI) Committee 325 [59] to provide a factor of safety of approximately three against bearing failures, signified by the formation of cracks in the concrete around the peripheral of the dowel.

GAPS IN KNOWLEDGE

The following is a list of topical items listed that the authors have identified as subjects for technological gaps in knowledge. These technology gaps are summarized as to the identification of the lack of knowledge (gap) along with a brief discussion of each topic. Topics are listed in no particular order.

Effects of moisture on fiber-reinforced polymer (FRP) dowels

Research concerning the use of fiber-reinforced polymer (FRP) dowel bars in place of steel dowel bars is ongoing [1,2,9,14,20,25,28,29,34,39,42,46,53,55]. By using FRP, corrosion due to moisture will be less likely. Other effects, however, of moisture on FRP dowel bars need to be studied. Possible expansion of the FRP dowel bar due to moisture absorption may cause an increase in stress in the concrete resulting in possible cracks and/or oblonging of the hole.

Aging of fiber-reinforced polymer (FRP) dowels

An investigation into aging effects of FRP dowel bars needs to be performed. A determination of how long an FRP dowel bar is good to use and if or when they will deteriorate needs to be made. If an FRP dowel bar does deteriorate then an acceptable level of deterioration needs to be determined so that the dowel bar will still be able to function properly. If deterioration is present in FRP dowel bars a comparison should also be made with the steel bars to see which dowel performs better [11,12,20].

Effects of road chemicals on FRP resin

If FRP dowel bars are structurally reasonable to use in jointed plain concrete pavement an investigation into the resin should be done. An exploration of how different resins resist different chemicals should take place. A determination of which fibers and resin are best able to withstand the effects of road salts, oils, acids, etc...also needs to be made. An investigation into which chemicals are detrimental to the resin and fibers of the FRP dowel bar and needs to take place [11,12,18,34].

Development of an FRP design procedure

If FRP is used as a viable dowel bar material, a procedure for the design of these dowels to resist forces that develop when transferring load is needed. All current theory, calculations, and design procedures for dowel bars are based on using circular steel dowel bars. If FRP is to be used as an alternative to steel in the fight against corrosion, then the theory behind FRP dowels will have to be researched and a new design procedure will have to be created [28,29,42].

Acceptable corrosion of steel dowel bars

Corrosion of steel dowels bars has been an on going battle. Steel bars have been epoxy coated in order to aid in the prevention of corroding. Many bars, however, are susceptible to corrosion even before they are placed in the concrete. Nicks during construction, manufacturing, moving, and placing all contribute to the wear of a dowel bar before it is placed. These dowel bars also see a good percentage of moisture during the concrete curing process. An investigation into how much corrosion of a steel dowel bar is acceptable needs to be determined. Exploring how much corrosion is acceptable before a steel dowel bar is considered useless, inadequate or causing joint lock up leading to its replacement would be extremely beneficial in the life and maintenance of a jointed plain concrete pavement [18,20].

Investigation of wheel load at pavement edge

Loads seen by dowel bars at or near the edge of a pavement will be different than those at the pavement centerline due to the smaller area over which to distribute the load. Changes in the bearing stresses and deflections of these dowel bars should be examined. Any affects on the dowel bars, slab and joints should also be noted. Investigation of the load at pavement edge should include but not be limited to the following variables: spacing, thickness of slab, and joint thickness.

Investigation of uneven dowel bar placement

The current practice when spacing dowel bars is to place them at an equal distance from one another at an on-center spacing. Lab and field-testing both need to be done in order to determine if other dowel bar spacing configurations are of any benefit. Investigating the placement of three or four dowel bars in the wheel path and one in between is suggested as an example of one of the variable placements to be investigated.

Curvature of slab effects on dowel when load placed in middle of slab

In order to determine the effects at the joint a concentrated wheel load is usually placed on either side of the slab joint. If a load, however, is placed in the center of the slab, between the joints, the joint and dowel bars will be affected differently. A consideration into how the dowel bar will react to this applied load needs to be taken into account. Slab and dowel bar stiffnesses, joint cracking, breaking and separation of the joint, and slab versus joint curvatures need to be investigated.

Bearing and contact surface stresses for shapes other than circular

The bearing stress on the concrete at the face of the joint is critical for proper function of the dowel bar in the concrete. If the bearing stress on the concrete becomes too large the concrete will begin to break away where it contacts the dowel bar. Repetitive high-stress loadings of the dowel bar-concrete interface will create a void. This void creates an additional amount of deflection in the system before the dowel bar will begin to take on the applied load. This additional deflection creates a loss in the efficiency of the dowel bar to transfer load across the joint. This loss in efficiency must now be carried by the sub grade, which puts an additional stress on the sub grade and creates the possibility for differential settlement of adjacent slabs. The bearing stress is directly related to the bearing surface. To obtain the allowable bearing stress, calculations use the width of a dowel bar. This width is for circular shapes. Investigations of elliptical and other shaped dowel bar's actual and allowable bearing stresses need to be completed to find out the affects of the bearing stresses due to surface shape. The additional related stresses along the length of the bar due to bearing contact and deflection for alternative-shaped dowel bars are also needed.

Modulus of dowel support, K_o , values for all shapes and sizes

The current procedure to determine how well a dowel bar will conduct shear transfer across a joint is to calculate its modulus of dowel support, K_o . There is disagreement among researchers today on what values should be used as the modulus of dowel support, K_o . Values for round steel dowels have been reported to range from 200,000 pci to 5,000,000 pci. This large discrepancy in range could be due to the theory behind the calculations. These calculations are based the theory defined by Friberg [52]. Friberg's theory behind the derivation of K_o was developed using a semi-infinite dowel length for a circular bar only. All dowel bars in use today are of finite length,

therefore making Friberg's equation in violation of its description. Furthermore, if a different dowel bar shape other than circular were to be examined, Friberg's theory would not apply. Therefore, a new analytical procedure is needed for comparing how well alternate-shaped (circular, elliptical, shaved, etc...) dowel bars conduct shear transfer across a joint. Developing a procedure that correctly evaluates these alternate-shaped dowel bars is vital in the understanding of the behavior of these dowel bars. The modulus of dowel bar support, K_o , needs to be reevaluated as an acceptable means of evaluating dowel bars [36].

Investigation of Load Transfer Efficiency of elliptical, circular, and other shaped dowels using different sizes and spacing

In an ideal situation, when a load is placed near a joint, the dowel bars would assume half the load and the remaining load is transferred to subgrade. However, no joint will behave in this ideal manner due to the repeated loadings seen by a pavement joint. This repetitive loading will create a small void and some load transfer efficiency of the dowel bar will be lost. In addition, when a wheel load is applied near a joint, not all dowel bars at the joint aid in transferring the load. The dowel bars closest to the applied wheel load transfer more of the load than the dowel bars furthest away from the applied load. An investigation into the load transfer efficiency of dowel bars should be conducted. This investigation should include circular, elliptical, and other shaped dowels at different of different sizes using different spacing and pavement thicknesses [41].

Further investigation of form factors (especially for shapes other than circles)

When calculating the relative deflection across a pavement joint four components are taken in to account. These components consist of the deflection of the dowel at each joint face, the deflection due to the slope of the dowel bar, the due to deflection, and the deflection due to shear. The calculations for shear deflection use a variable form factor. This form factor is in question. The form factor for a solid circular section is 10/9. Other shape form factors, however, need to be determined in order to calculate the correct shear deflection for the respective alternative shape [41].

The relationship between $K_o b$ (modulus of foundation) versus $K_o y_o$ (bearing stress), needs to be determined for different shapes

In calculating the modulus of dowel support the last step is to create a graph of the modulus of dowel support versus deflection, y_o , at the face of the joint. By imputing the geometric properties for the dowel bar and substituting multiple values of K_o into a theoretical equation the deflection at the face of the joint is determined. Using the modulus of dowel support and the deflection at the face of the joint, the concrete bearing stress can be calculated. The value of y_o is dependant on the shape of the dowel bar. The value b , width of the dowel bar, is also dependant on the shape of the dowel bar. These two values y_o and b need to be investigated for shapes other than circular.

Modifications of the AASHTO T253 test procedure are needed to identify the true inflection point of the dowel bar.

Modifications to the current Load-Deflection Test Procedure portion of the AASHTO T253 test should be made. Many methods and qualifications for the current test procedure are outdated or inadequate for today's standards. The following are proposed modifications to the Load-Deflection Test Procedure portion of AASHTO T253:

- The specimens should be molded with a 1/8-inch gap in between sections, as in accordance with standard practice, as opposed to the test method's recommended 3/8-inch gap. Provisions are needed (as well as parameter studies) for the effects of various gap widths.
- Specimen dimensions should be changed according to pavement thickness.
- The ends of the specimen should be held down well enough in order to prevent rotation and instrumentation should be stipulated to monitor possible rotation.
- The bottom sides of the specimen need to be cast in plaster in order to be flush with the testing machine.
- An amount of allowable end rotation needs to be determined as to not void the test results.
- A new applied load rate and higher applied load need to be determined in order to construct better deflection versus load diagrams.
- A new maximum allowable deflection across the joint should be determined for design.
- The specimen should be loaded using point loads located at the ends of the interior section and not uniformly, pending inflection point investigation.

Updating this test will yield results more suitable to field application and allow different dowel bars to be compared. By modifying this test, a universal procedure may be used in order to determine and evaluate K_o and the concrete bearing stress underneath any dowel bar [2].

Standardized testing procedures and ASTM Tests should be developed for dowel bars.

Current ASTM testing procedures are inadequate or out dated for use with today's dowel bar technology. Many of these tests specify changes in the dowel bar specimens, which in turn, changes the characteristics of the dowel bars and produces erroneous or unrealistic results. In order to develop and use fiber-reinforced dowel bars, testing needs to be developed and standardized. Some of the standard tests and their weaknesses, for example, used currently for dowel bar research:

ASTM D 3916: Standard Test Method for Tensile Properties of Pultruded Glass-Fiber-Reinforced Plastic Rod. This test is to be used on plastic rod of diameters ranging from 3.2 mm (1/8 in.) to 25.4 mm (1 in.). However, most dowel bars currently in use today are 1.5 inches in diameter [62].

ASTM D 4255/D 4255M: Standard Test Method for Testing In-plane Shear Properties of Composite Laminates. This test calls for a flat rectangular plate to be tested [62].

ASTM D 790: Standard Test Method for Flexural Properties of Unreinforced and Reinforced Plastics and Electrical Insulating Materials. This test calls for a bar of rectangular section to be used as a sample [62].

These tests, among others, use samples not conducive to the dowel bar shape and size. The development of standardized FRP dowel bar testing will need to take place in order to advance dowel bar technology.

Investigate the effects of oblonging of the hole for large number of cycles.

After a significant number of vehicles have passed over the joint an oblonging where the dowel bar contacts the concrete can occur. This oblonging creates a void space formed due to a stress concentration where the dowel contacts the concrete at the joint face directly above and below the dowel. Over time, the repeated process of traffic traveling over the joint crushes the concrete surrounding the dowel and causes a void in the concrete. This void inhibits the dowels ability to transfer load across the joint. An investigation into this oblonging for a large number of cycles using circular, elliptical and other shaped dowel bars needs to be done.

A universal procedure needs to be created so that any type of bar may be evaluated.

Full parameter studies are needed to formulate design and behavior for the interrelationships of: spacing, size, material, pavement thickness, loads, joint width, and shapes for any size or shaped dowel bar.

Investigate criteria for large planes on runways and taxiways.

Using dowel bars to transfer loads in runways and taxiways also needs to be researched. A determination of whether or not the same dowel bars used in highway jointed plain concrete pavement can be used in runways and taxiways needs to be made. The effect of impact loading on these dowel bars also needs to be investigated.

Investigate theory change for dowels used as expansion joints and larger joint widths.

As the joint width increases, as may be the case for expansion joints in cold weather, the load transfer efficiency of the dowel bar may decrease. An investigation into the theory behind dowel bars used in expansion joints and larger joint widths needs to take place in order to determine whether or not the current dowel bar theory practiced is adequate.

A distinction between whether laboratory and field measurements are true needs to be made.

In order to determine the true characteristics of the dowel bars, a method for determining whether or not true measurements are being taken is needed. A relation between accelerated/repeated load tests vs. actuators in the lab needs to be determined and a way to obtain more consistent concise field measurements is also needed.

Need fatigue for a large number of cycles, (e.g. 10-60 million cycles for full-scale lab tests) and correlate with field cyclic results.

This fatigue relation needs to be done with both steel and FRP with different shapes, sizes and spacing. This task will also aid in determining whether or not field and laboratory results are true measurements.

RECOMMENDATIONS AND CONCLUSIONS

As dowel bar technology advances, many of the past theories, equations and procedures should be questioned and challenged. Designing dowel bars in the future utilizing different sizes, shapes, spacings and materials will call for different equations and procedures. This report provides a summary of past dowel bar work and focuses on the gaps in knowledge that must be accommodated for future design considerations.

The more significant gaps in technology for dowel bar design and analysis are listed and described in Section 5.0 of the report. These significant gaps were concluded to be the following (not in priority order):

- Effects of moisture on FRP dowels
- Aging of FRP dowels
- Effects of road chemicals on FRP resin
- Development of FRP design procedure
- Acceptable corrosion of steel dowel bars
- Investigation of wheel load at pavement edge
- Investigation of uneven dowel bar placement
- Curvature of slab effects on dowel when load placed in middle of slab
- Bearing and contact surface stresses for shapes other than circular
- Modulus of dowel support, K_o , values for all shapes and sizes
- Investigation of Load Transfer Efficiency of different shaped dowels at different spacings
- Investigation of form factors
- The relationship between the modulus of foundation versus bearing stress for different dowel bar shapes
- Modifications to the AASHTO T253 test procedure
- Standardizing testing procedures and ASTM tests for dowel bars
- Investigation into the effects of oblonging of the hole for a large number of cycles
- Development of a universal design procedure
- Investigate criteria for large planes on runways and taxiways
- Investigate theory change for dowels used as expansion joints and larger joint widths
- A distinction between whether laboratory and field measurements are true needs to be made
- Fatigue for a large number of cycles correlated with field cyclic results

Of the above-listed technology gaps in knowledge, the authors recommend that universal testing procedures for both laboratory and field conditions first be determined so that a correct,

consistent comparison between dowel bars can be made. While developing these procedures, the past dowel bar theory as proposed by Friberg and others needs revision to accommodate changes in shape, materials, spacings and sizes. Close attention should be paid to the accuracy of past theory, particularly the use of the modulus of dowel bar support, K_o . In order to achieve adequate comparative results, a standardize dowel bar testing procedure is vitally important.

Only after revised theories and testing procedures are obtained should dowel bar technology advance for highway pavements and other structures so as to keep the industry from spending money unnecessarily. An organizational method is needed to keep all interested parties informed and up to date on the advancement of the solutions to the technological gaps in dowel bar design changes, as new dowel bar sizes and shapes become available.

REFERENCES

1. Porter, M.L., B. Barnes, B. Hughes, and K. Viswanath. *Non-Corrosive Tie Reinforcing and Dowel Bars for Highway Pavement Slabs, Final Report*. HR-343 Submitted to Highway Division of the Iowa Department of Transportation and Iowa Highway Research Board. Iowa State University, Engineering Research Institute, Ames, IA, November 1993.
2. Porter, M.L., D. Davis, R. Guinn, Jr., A. Lundy, and J. Rohner. *Investigation of Glass Fiber Composite Dowel Bars For Highway Pavement Slabs, Final Report*. TR-408 Submitted to Highway Division of the Iowa Department of Transportation and Iowa Highway Research Board. Iowa State University, Engineering Research Institute, Ames, IA, June 2001.
3. Kelleher, K., and R.M. Larson. *The Design of Plain Doweled Jointed Concrete Pavement*. Proceedings of the Fourth International Conference on Concrete Pavement Design and Rehabilitation. Purdue University, West Lafayette, Indiana, April 18-20, 1989.
4. Innovative Pavement Research Foundation. *Concrete Pavement Research and Technology An Annotated Bibliography*. Research Reports and Findings. Prepared by Applied Pavement Technology, Inc. Oakbrook Terrace, IL, April 2001.
5. Federal Highway Administration (FHWA). *Concrete Pavement Joints*. FHWA Technical Advisory T 5040.30. Federal Highway Administration, Washington, DC. November 1990.
6. Ioannides, A.M. and G.T. Korovesis. Aggregate Interlock: A Pure-Shear Load Transfer Mechanism. *Transportation Research Record* 1286. Transportation Research Board, Washington, DC, 1990.
7. Ioannides, A.M., Y.H. Lee, and M.I. Darter. Control of Faulting Through Joint Load Transfer Design. *Transportation Research Record* 1286. Transportation Research Board, Washington, DC, 1990.
8. Kunt, M.M. and B.F. McCullough. Evaluation of the Subbase Drag Formula by Considering Realistic Subbase Friction Values. *Transportation Research Record* 1286. Transportation Research Board, Washington DC, 1990.
9. Larralde, J. Feasibility of Class C FRP Load Transfer Devices for Highway Jointed Concrete Pavements. *Serv Durability Construction Materials Proc First Materials Engineering Congress*. Published by ASCE, Boston Society of Civil Engineers Sect, Boston, MA, 1990.
10. American Concrete Pavement Association (ACPA). Design and Construction of Joints for Concrete Highways. TB-010.0 D. *American Concrete Pavement Association*. Arlington Heights, IL, 1991.
11. Porter, M.L., M.D. Albertson, B.A. Barnes, E.A. Lorenz, and K.P. Viswanath. *Thermoset Composite Concrete Reinforcement: Part 1 Final Report*. HR-325 Submitted to Iowa

Department of Transportation and Iowa Highway Research Board. Iowa State University, Engineering Research Institute, Ames, IA, May 1992.

12. Porter, M.L., E.A. Lorenz, B.A. Barnes, and K.P. Viswanath. *Thermoset Composite Concrete Reinforcement: Part 2 Final Report*. HR-325 Submitted to Iowa Department of Transportation and Iowa Highway Research Board. Iowa State University, Engineering Research Institute, Ames, IA, October 1992.
13. Poli, S.D., M. Di Prisco, and P.G. Gambarova. Shear Response, Deformations, and Subgrade Stiffness of a Dowel Bar Embedded in Concrete. *ACI Structural Journal*, V. 89, No. 6, November-December 1992, pp. 665-675.
14. Lorenz, E.A. Accelerated Aging of Fiber Composite Bars and Dowels. Masters Thesis. Iowa State University, 1993.
15. Sargand, S.M. and G.A. Hazen. *Evaluation of Pavement Joint Performance Final Report*. #14474(0) Submitted to Ohio Department of Transportation and Federal Highway Administration. Ohio University, January 1994.
16. Moore, Raymond K. *Analysis, Design, and Construction of Transverse Joint Load Transfer Systems for Rigid Pavement Final Report*. Submitted to K-TRAN Project KU-93-6. University of Kansas, December 1994.
17. McGhee, K.H. *Design, Construction, and Maintenance of PCC Pavement Joints*. NCHRP Synthesis of Highway Practice 211. Transportation Research Board, Washington, DC, 1995
18. American Society of Civil Engineers. *Coating Protection for Reinforcement: State of the Art Report*. American Society of Civil Engineers. Thomas Telford Limited, London, England, 1995.
19. Vandenbossche, J.M. *An Analysis of the Longitudinal Reinforcement in a Jointed Reinforced Concrete Pavement*. M.S. Dissertation. Michigan State University, East Lansing, MI, 1995.
20. Porter, M.L., J. Mehus, and K. Young. *Aging Degradation of Fiber Composite Reinforcements for Structural Concrete*. Iowa State University, Engineering Research Institute, Ames, IA, September 1995.
21. Proctor, B.A., D.R. Oakely, and Litherland, K.L., Developments in the Assessment and Performance of GRC Over 10 Years. *Composites*, Volume 13, Number 2, 1982, pp: 173-179.
22. Litherland, K.L., and D.R. Oakely, "The Use of Accelerated Ageing Procedures to Predict the Long Term Strength of GRC Composites", *Cement and Concrete Research*, Volume 11, Number 3, 1981, pp: 455-466.
23. Aindow, A.J., D.R. Oakely, and B.A. Proctor, "Comparison of the Weathering Behavior of GFC with Predictions Made from Accelerated Aging Tests", *Cement and Concrete Research*, Volume 14, Number 2, 1983, pp: 271-274.

24. Oakley, D.R., K.L. Litherland, and B.A. Proctor, *The Development of a Method of Predicting the Weathering Behavior of Glass Reinforced Cement Composites*. Proceedings 2nd International Conference on Durability of Building Materials and Components, Gaithersburg, MD, September, 1981, pp: 225-231.
25. Litherland, K.L., *Test Methods for Evaluating The Long Term Behavior of GFRC* Proceedings – Durability of Glass Fiber Reinforced Concrete Symposium, Prestressed Concrete Institute, Holiday Inn Mart Plaza, Chicago, IL, November 12-15, 1985.
26. Beegle, D.J. and S.M. Sargand. *Three-Dimensional Modeling of Rigid Pavement*. Final Report Submitted to Ohio Department of Transportation and Federal Highway Administration. Ohio University, September 1995.
27. Bischoff, D.L. *Random Skewed Joints With and Without Dowels Final Report*. WI 85-01. Wisconsin Department of Transportation, Madison, WI, December 1996.
28. Porter, M.L. and R.L. Braun. *Summary of Glass Fiber Reinforced Plastic Dowel Bar Research at Iowa State University*. Iowa State University, Engineering Research Institute, Ames, IA, June 1996.
29. Porter, M.L. and R.L. Braun. *Preliminary Assessment of the Potential Use of Alternative Materials for Concrete Highway Pavement Joints*. Iowa State University, Engineering Research Institute, Ames, IA, January 1997.
30. Sargand, S.M. and E. Cinadr. *Field Instrumentation of Dowels*. Final Report Submitted to Ohio Department of Transportation and Federal Highway Administration. Ohio University, May 1997.
31. Ambroz, J.K., W.J. Seiler, and M.I. Darter. *Load Transfer Design and Benefits for Portland Cement Concrete Pavements*. Report No. 96-128-E1. American Highway Technology, Kankakee, IL, 1997.
32. Hammons, M.I. and A.M. Ioannides. *Mechanistic Design and Analysis Procedure for Doweled Joints in Concrete Pavements*. Proceedings, Sixth International Purdue Conference on Concrete Design and Materials for High Performance. Purdue University, West Lafayette, IN, 1997.
33. Jiang, Y.J. and M.I. Darter. *Prevention of Joint Faulting Based on Field Performance Modeling*. Proceedings, Sixth International Purdue Conference on Concrete Design and Materials for High Performance. Purdue University, West Lafayette, IN. 1997.
34. Eddie, D. *Fiber Reinforced Polymer Dowels for Concrete Pavements*. Masters Thesis. University of Manitoba, May 1999.
35. Evans, L.D. SHRP Joint Study: A Seven-Year Look. Preprint No. 990843. Seventy-Eighth Annual Meeting of the Transportation Research Board, Washington, DC. 1999.

36. Mannava, S.S., T.D. Bush, Jr., and A.R. Kukreti. Load-Deflection Behavior of Smooth Dowels. *ACI Structural Journal*, V. 96, No. 6, November-December 1999, pp. 891-898.
37. Cable, J.K. and L.I. Wosoba. *Matching Load Transfer to Traffic Needs*. Mid-Continent Transportation Symposium 2000. Iowa State University, Ames, IA. May 15-16, 2000.
38. Federal Highway Administration (FHWA). *LTPP Findings Pay Off for Pennsylvania*. Report No. FHWA-RD-00-064. Federal Highway Administration, McLean, VA. February 2000.
39. Eddie, D., A. Shalaby, and S. Rizkalla. Glass Fiber-Reinforced Polymer Dowels for Concrete Pavements. *ACI Structural Journal*, V. 98, No. 2, March-April 2001, pp. 201-206.
40. Sargand, Shad M. *Performance of Dowel Bars and Rigid Pavement*. Final Report Submitted to Federal Highway Administration and U.S. Department of Transportation. Ohio University, June 2001.
41. Porter, M.L., R. Guinn, Jr., and A. Lundy. *Dowel Bar Optimization: Phases I and II, Final Report*. Submitted to Center for Portland Cement Concrete Pavement and American Highway Technology. Iowa State University, October 2001.
42. Davis, D. *Fatigue Behavior of Glass Fiber Reinforced Polymer Dowels*. Masters Thesis. Iowa State University, 2001.
43. Snyder, M.B., R.A. Embacher, and T.D. Odden. Using the Minnesota Accelerated Loading Facility to Test Retrofit Dowel Load Transfer Systems. *Transportation Research Record* No. 1769, 2001, pp.134-141.
44. Neff, T. Fax of current dowel bar projects from his database to author. January 25, 2002.
45. Ioannides, A.M., G.T. Korovesis. Analysis and Design of Doweled Slab-on-Grade Pavement Systems. *Journal of Transportation Engineering*, Vol. 118, No. 6, November/December 1992, pp. 745-768.
46. Brown, V.L. and C.L. Bartholomew. *FRP Dowel Bars in Reinforced Concrete Pavements*. Proceedings of the International Symposium on FRP Reinforcement for Concrete Structures. American Concrete Institute (ACI), Michigan, 1993.
47. American Concrete Pavement Association (ACPA). *Design and Construction of Joints for Concrete Highways*. ACPA, Skokie, Illinois, 1991.
48. American Association of State Highway and Transportation Officials (AASHTO). *AASHTO Guide for Design of Pavement Structures*. AASHTO, Washington, D.C., 1993.
49. Huang, Y.H. *Pavement Analysis and Design*. Prentice Hall, Inc., New Jersey, 1993.
50. Teller, L.W. and H.D. Cashell. Performance of Doweled Joint Under Repetitive Loading. *Public Roads*, Vol. 30, No.1, April 1958, pp. 1-24.

51. Timoshenko, S. and J.M. Lessels. *Applied Elasticity*. Westinghouse Technical Night School Press, Pennsylvania, 1925.
52. Friberg, B.F. Design of Dowels in Transverse Joints of Concrete Pavements. *Transactions, American Society of Civil Engineers*. Vol. 105, No. 2081, 1940.
53. Albertson, M.D. *Fibercomposite and Steel Pavement Dowels*. Masters Thesis. Iowa State University, 1992.
54. Bradbury, R.D., *Design of joints in concrete pavements*. Proceedings, 12th Annual Meeting of the Highway Research Board. pp. 105-141, Washington D.C., 1932
55. Porter, M.L., D. Davis, and J. Rohner. *Investigation of Glass Fiber Composite Dowel Bars for Highway Pavement Slabs: Progress Report TR-408*. Submitted to Project Development Division of the Iowa Department of Transportation and Iowa Highway Research Board. Ames, IA, January 1999.
56. Friberg, B.F., *Load and deflection characteristics of dowels in transverse joints of concrete pavements*. Proceedings, 18th Annual Meeting of the Highway Research Board, National Research Council, pp. 140-154, Washington D.C., 1938.
57. Grinter, L.E., Discussion of “Design of dowels in transverse joints of concrete pavements,” by B.F. Friberg, *Transactions, American Society of Civil Engineers*. Vol. 105, pg. 1096-1101, New York, NY, 1940.
58. Yoder, E.J. and M.W. Witzak. *Principles of Pavement Design*. 2nd ed. John Wiley & Sons, Inc., New York, 1975.
59. ACI Committee 325. Structural Design Considerations for Pavement Joints. *Journal of the American Concrete Institute*, Vol. 28, No. 1, July 1956, pp. 1-28.
60. Westergaard, H.M. Computation of Stresses in Concrete Roads. *Proceedings, 5th Annual Meeting of the Highway Research Board*, Washington, D.C., 1925.
61. Tabatabaie, A.M., E.J. Barenburg, and R.E. Smith. *Longitudinal Joint Systems in Slipformed Rigid Pavements: Vol. II-Analysis of Load Transfer Systems for Concrete Pavements*. Report No. DOT/FAA.RD-79/4, Federal Aviation Administration, U.S. Department of Transportation, 1979.
62. American Standard for Testing and Materials (ASTM). Annual Book of ASTM Standards. ASTM, Pennsylvania, 2000.